

## M250-10E - ELECTRIC POWER

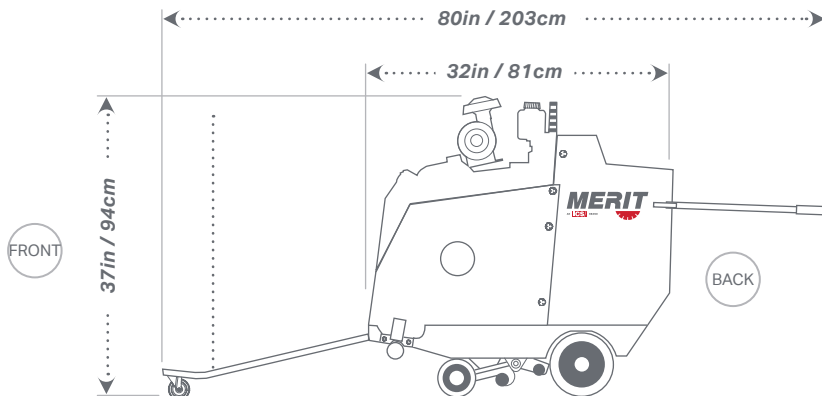

LEFT SIDE VIEW

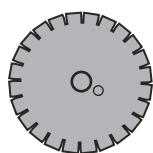

**14in- 24in**  
35cm - 61cm

**10in/25cm Max Cut**

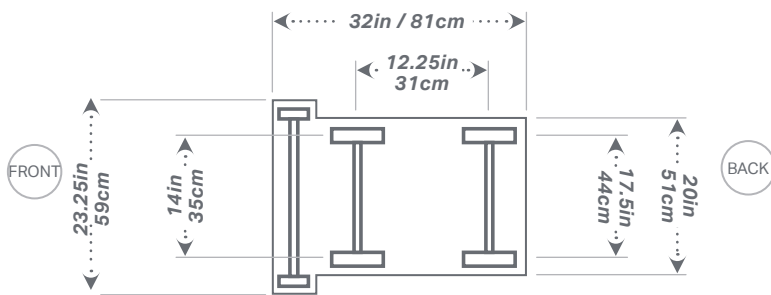

BOTTOM VIEW

### SPECIFICATIONS

<b>Raise &amp; Lower Control</b>	Manual
<b>Air Filter</b>	N/A
<b>Blade Mounting</b>	Left and right
<b>Blade Shaft Drive</b>	1in / 2.5cm with 4in / 10cm arbors
<b>Approx. Weight</b>	425lbs. / 218kg.
<b>Drive Speed</b>	0-200 FPM
<b>Depth Control</b>	Manual
<b>Spindle Size</b>	1.25in / 3cm with tapered roller bearings
<b>Arbor Size</b>	1in / 2.5cm
<b>Engine Manufacturer</b>	Baldor
<b>Voltage</b>	480V 3-phase

BLADE GUARD IN	BLADE GUARD CM
14 x 2	35.5 x 5
18 x 2	46 x 5
20 x 2	50 x 5
24 x 2	61 x 5

Part Number	Description
M250-10E-SP	M250, 10HP, ELECTRIC, SELF-PROPELLED FLAT SAW