

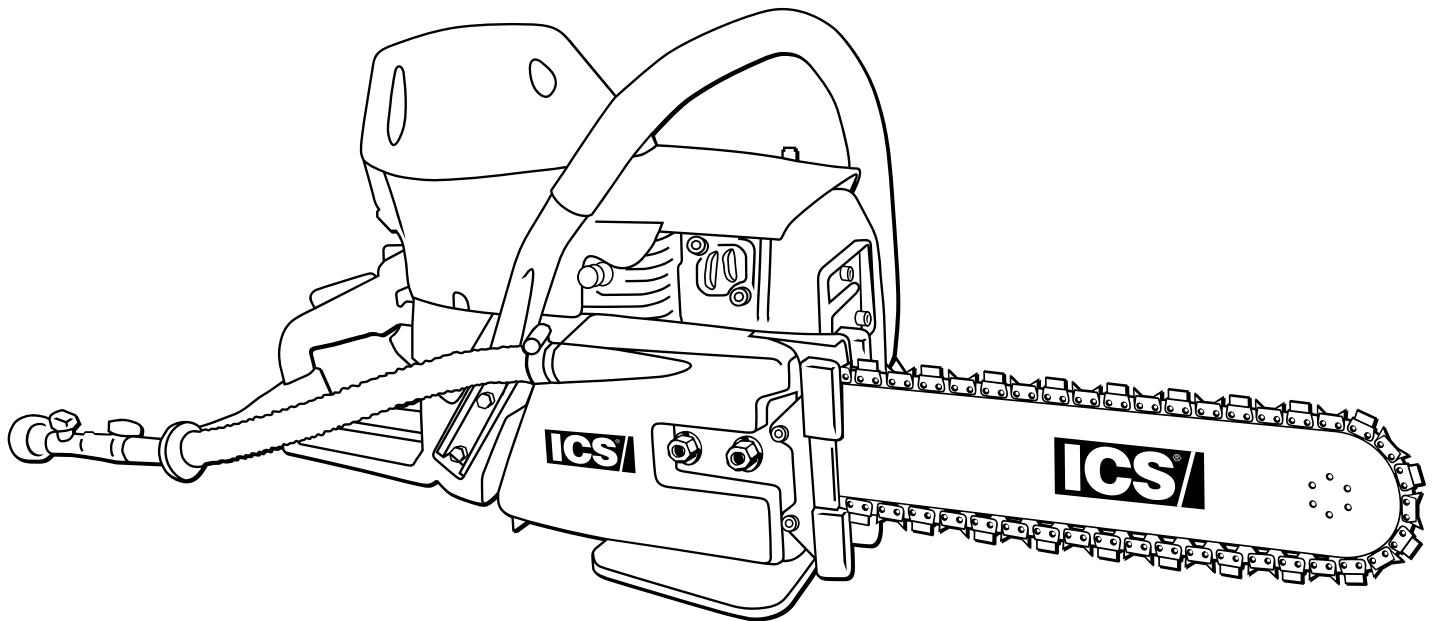

660GC



SERVICE MANUAL

660GC SERVICE MANUAL

SECTION	SECTION TITLE	PAGE NUMBER
	SERVICE MANUAL USE	2
1	TOOLS	3
2	SAW SPECIFICATIONS	4
3	SERIAL NUMBER LOCATION	5
4	SPARE PARTS DIAGRAMS (TORQUE SPECS & LOCTITE® APPLICATION)	6
5	AIR INTAKE	19
6	SPARK PLUG	21
7	CLUTCH & RIM SPROCKET	23
8	STARTER SYSTEM	27
9	WALLWALKER®	33
10	CYLINDER COVER	35
11	MUFFLER	39
12	CARBURETOR	41
13	CYLINDER & PISTON	43
14	WATER HOSE	52
15	IGNITION COIL	53
16	FLYWHEEL	55
17	FRONT HANDLE	57
18	FUEL TANK	58
19	CRANKCASE	60
20	BAR STUDS & BAR PAD	68
21	CHAIN TENSIONER	69
22	CARBURETOR TUNING	70
23	IDLE SPEED ADJUSTMENT	74
24	TROUBLESHOOTING DIAGRAMS	75
25	TROUBLESHOOTING FUEL SYSTEM LEAKS	77
26	TROUBLESHOOTING CRANKCASE LEAKS	80
	APPENDIX	
	1. SPARK PLUG REFERENCE GUIDE	81

Service Manual Use

This manual contains all the technical information necessary for carrying out repairs on the 660GC saw. For safe, efficient work, it is of prime importance that the values indicated be adhered to. Routine periodic maintenance is covered in the operator's manual included with each saw.

General Shop Rules

- Always use the right tools for the job, otherwise components may be damaged.
- Use a plastic dead blow mallet to separate parts attached solidly to each other.
- Mark mating parts as a reassembly reference.
- Keep component parts together as a group. Assemble screws and nuts into appropriate subgroups.
- When reassembling, clean all parts carefully, lubricate moving parts and replace all oil seals, o-rings, gaskets, washers and self-locking nuts.
- **For best results, use only original ICS[®] replacement parts.**

General Recommendations

- Some procedures in this manual require the use of special tools. A complete tool kit for ICS[®] saws is available from ICS[®].
- Detailed carburetor maintenance and overhaul information is available in Walbro's Diaphragm Carburetor Service Manual. Walbro can be contacted at <http://www.walbro.com> or by calling 1.989.872.2131.

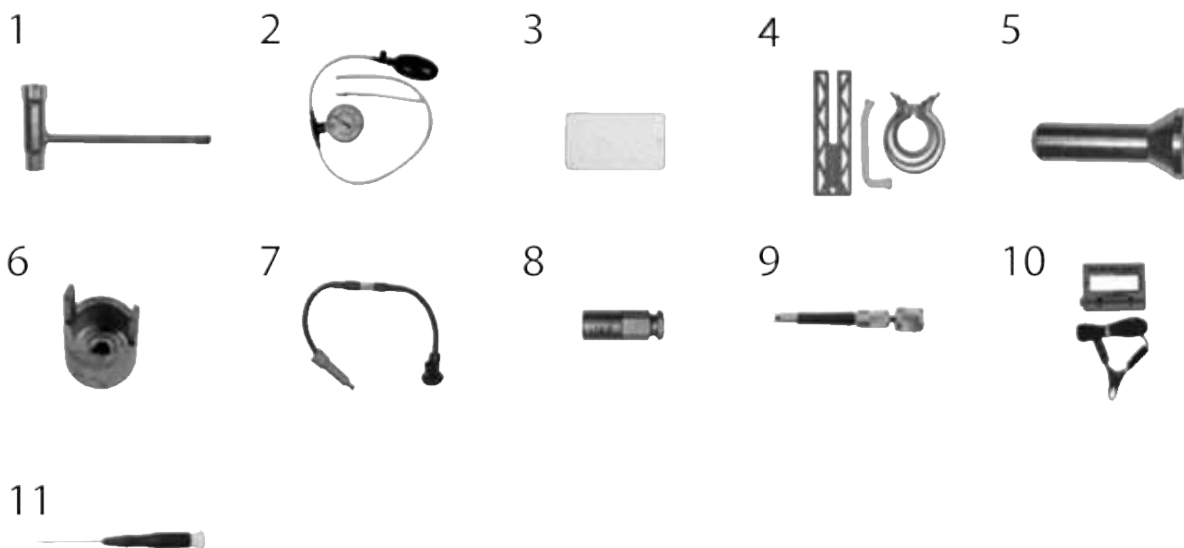

Key #	Part No.	Description	MSRP
1	71521	Scrench 13-19 mm	\$10.55
2	71541	Pressure Gauge Bulb	\$47.40
3	71542	Coil/Flywheel Timing Shim	\$5.25
4	71543	Cylinder Assembly Clamps & Piston Stop	\$10.55
5	73462	Main Bearing Driver Tool	\$38.65
6	71546	Shock Absorber Tool	\$22.15
7	71547	Spark Tester	\$46.35
8	71548	Flywheel Disassembly Tool	\$31.45
9	71550	Limiter Cap Puller	\$89.25
10	71565	Electronic Tachometer	\$240.00
11	71573	Tuning Screwdriver	\$10.55
Not Shown	71625	Carburetor Tuning Kit	\$99.95
Not Shown	505882	2-Stroke Oil, 25:1 Mix, 5.2 oz (158 ml) (6-Pack)	\$18.00
Not Shown	505883	2-Stroke Oil, 25:1 Mix, 5.2 oz (158 ml) (24-Pack)	\$55.00

SPECIFICATIONS

Engine Type	2-stroke Single Cylinder Air Cooled
Displacement	3.9 cu-in (64 cc)
Horsepower	4.2 HP (3.1 kw) @ 9,500 RPM
Torque	32 in-lbs (3.6 Nm) @ 6,000 RPM
Engine Speed	11,500 +/- 500 rpm (max) 2,800-3,200 rpm (idle)
Weight	18.2 lbs (8.3 kg) without guidebar and diamond chain
Cut Depth	Up to 10 inches (25.4 cm)
Dimensions	17 inches (44 cm) length 10 inches (25.5 cm) height 11.6 inches (29.5 cm) width
Air Filter	Water Resistant Polyester
Carburetor	Walbro HDA225
Starter	Dust and Water resistant
Ignition	Special water resistant electronic ignition
Clutch	Centrifugal three shoe, single spring
Fuel Mix ratio	25:1 (4%)
Fuel Capacity	0.26 gallons (1 Liter)
Water Supply	Minimum 20 psi (1.5 bar)
Water Flow	Minimum 2 gpm (8 lpm)
Noise Level	101 dB at 3 ft (1m)
Vibration Level	6.2 m/s ² (front handle) 7.3 m/s ² (rear handle)
Engine Break-in Period	One tank, without cutting, cycling throttle
Spark Plug	Champion CJ7Y, Bosch BWS7F, or NGK BPMR7A. Electrode gap .020 in (0.5 mm)

3 660GC serial number series.

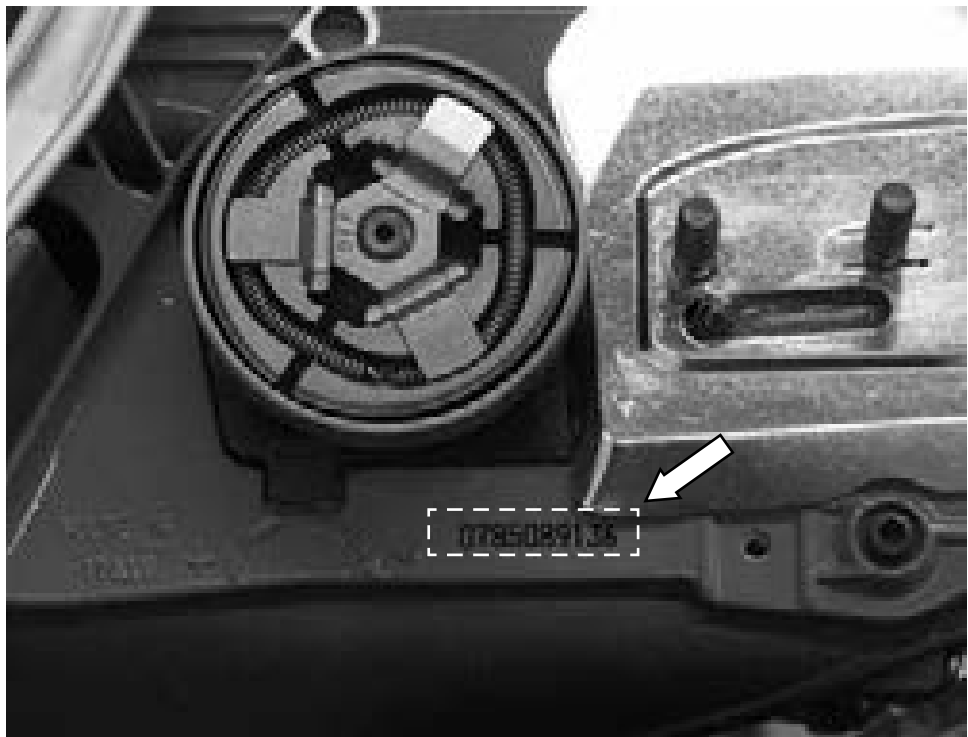

4 This section covers torque, Loctite®, and lubrication requirements of the individual components. The key numbers used are not related to the key numbers in the 660GC Replacement Parts Price List.

CYLINDER & PISTON ASSEMBLY

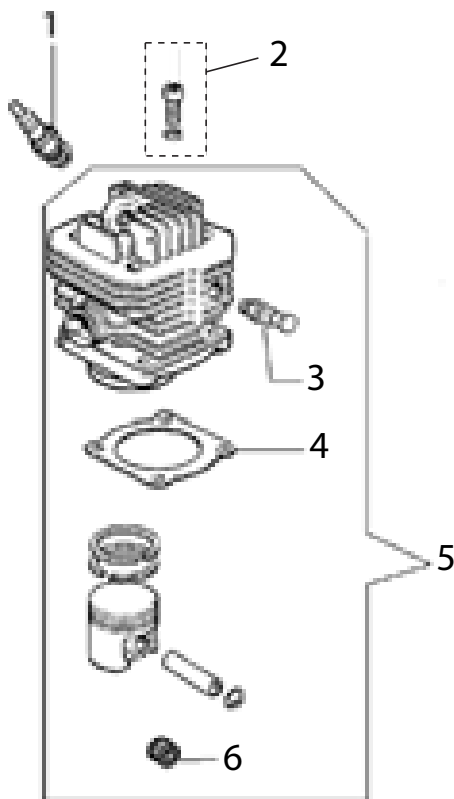

KEY	DESCRIPTION	TORQUE		LOCTITE® 242	PART NUMBER
		Nm	in-lbs.		
1	SPARK PLUG	27.5	243		73199
2	CYLINDER BOLT	10.7	95	X	73874
3	DECOMPRESSION VALVE	12.8	113		71642
4	CYLINDER BASE GASKET				505439
5	COMPLETE CYLINDER & PISTON ASSEMBLY				505428
6	WRIST PIN NEEDLE BEARING				505403

CRANKCASE ASSEMBLY

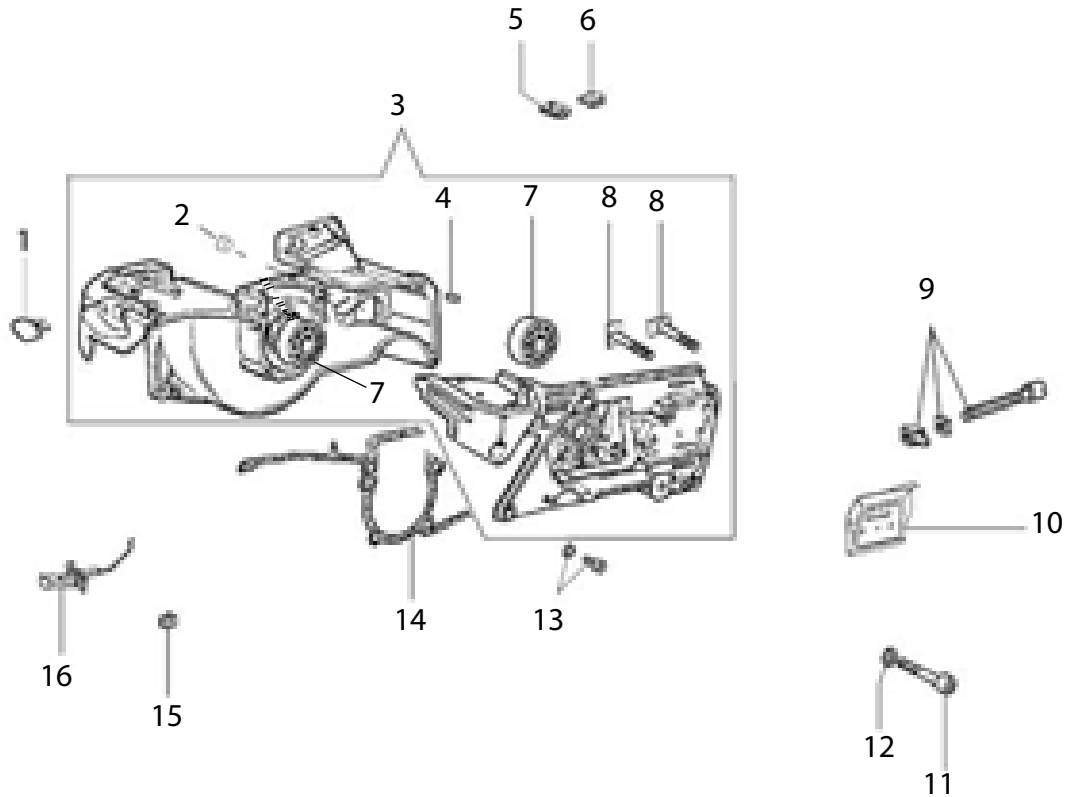

KEY	DESCRIPTION	TORQUE		LOCTITE® 242	PART NUMBER
		Nm	in-lbs.		
1	CRANKCASE PLUG				505407
2	TANK PLUG				512461
3	CRANKCASE				537665
4	CRANKCASE DOWEL PIN				73281
5	FUEL LINE GROMMET				505627
6	CRANKCASE GROMMET				505408
7	CRANKSHAFT BEARING				505375
8	BAR MOUNTING STUD				509555
9	TENSIONER				505393
10	BAR MOUNT PAD COVER PLATE				505467
11	SCREW, 5 X 50 mm	4.9	43	X	509709
12	WASHER				73897
13	CRANKCASE BOLT	7.9	69	X	73930
14	CRANKCASE GASKET				505440
15	CHOKE LEVER BUSHING				73955
16	CHOKE LEVER				505409

CLUTCH & CRANKCASE ASSEMBLY

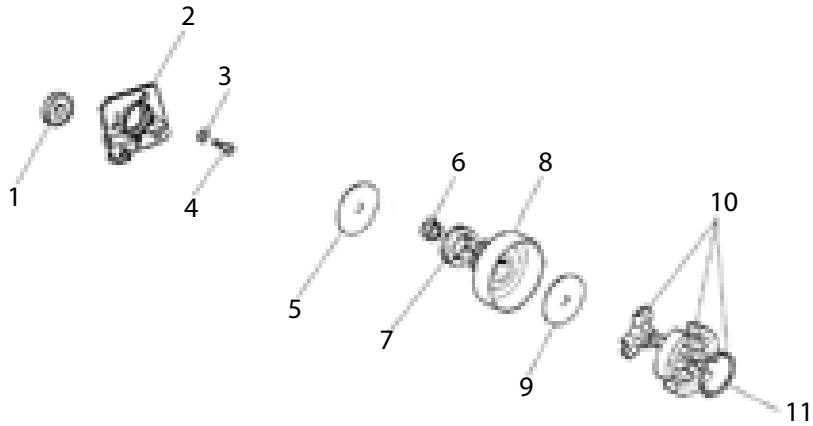

KEY	DESCRIPTION	TORQUE		LOCTITE® 242	PART NUMBER
		Nm	in-lbs.		
1	CRANKSHAFT RETAINER SEAL				540139
2	CRANKCASE SEAL RETAINER				505423
3	WASHER				73285
4	BOLT	2.9	26	X	73940
5	CLUTCH SPACER				505421
6	CLUTCH BEARING				505378
7	8T RIM SPROCKET KIT				70949
8	CLUTCH CUP WITH SPLINED ADAPTOR				505422
9	CLUTCH SPACER INSIDE				505436
10	CLUTCH	33.3	295		505442
11	CLUTCH SPRING				505434

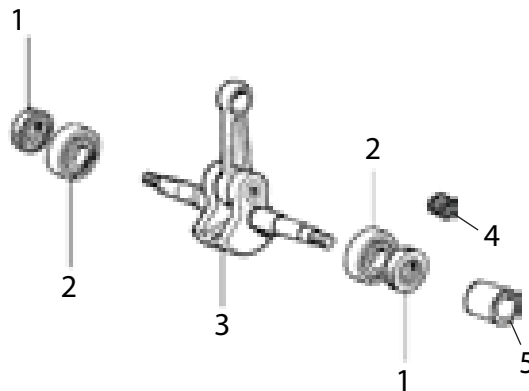

KEY	DESCRIPTION	TORQUE		LOCTITE® 242	PART NUMBER
		Nm	in-lbs.		
1	CRANKSHAFT SEAL				505381
2	CRANKSHAFT BEARING				505375
3	CRANKSHAFT ASSEMBLY				505397
4	WRIST PIN NEEDLE BEARING				505403
5	CRANKSHAFT BUSHING			X	509487

MUFFLER ASSEMBLY

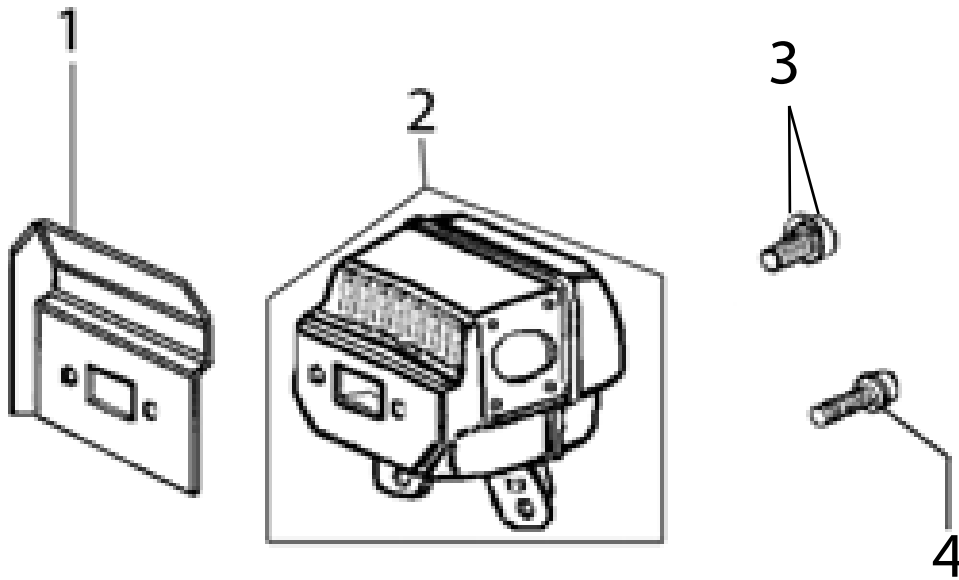

KEY	DESCRIPTION	TORQUE		LOCTITE® 242	PART NUMBER
		Nm	in-lbs.		
1	CYLINDER-TO-MUFFLER GASKET				505385
2	MUFFLER				537692
3	MUFFLER SCREW & WASHER	8.8	78		548518f
4	LOWER MUFFLER SCREW	5.8	52		73866

CARBURETOR ASSEMBLY

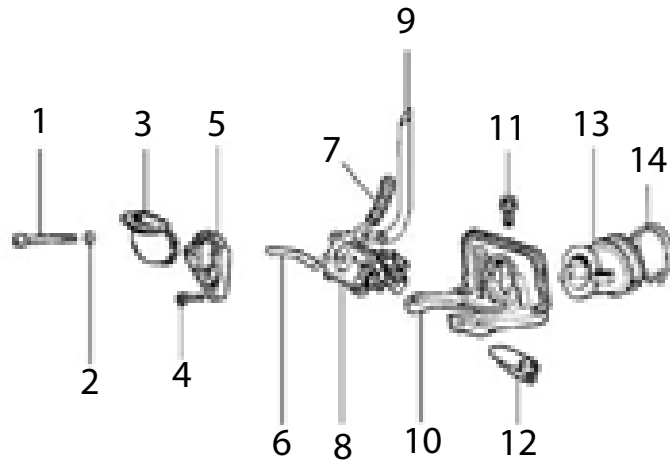

KEY	DESCRIPTION	TORQUE		LOCTITE® 242	PART NUMBER
		Nm	in-lbs.		
1	SCREW	4.9	43		505469
2	WASHER				73897
3	OUTER INTAKE MANIFOLD				507427
4	OUTER INTAKE MANIFOLD FLANGE SCREW	4.9	43	X	73901
5	OUTER INTAKE MANIFOLD FLANGE				505384
6	COMPENSATOR TUBE				505382
7	CARBURETOR SPRING				73888
8	CARBURETOR, WALBRO				517742
9	PULSE TUBE				71751
10	CARBURETOR MOUNTING BRACKET				505411
11	SCREW	4.0	35	X	73866
12	ADJUSTMENT GUIDE				505391
13	INTAKE MANIFOLD				505383
14	INTAKE MANIFOLD CLAMP	1.0	11		73867

FUEL TANK & HANDLE ASSEMBLY

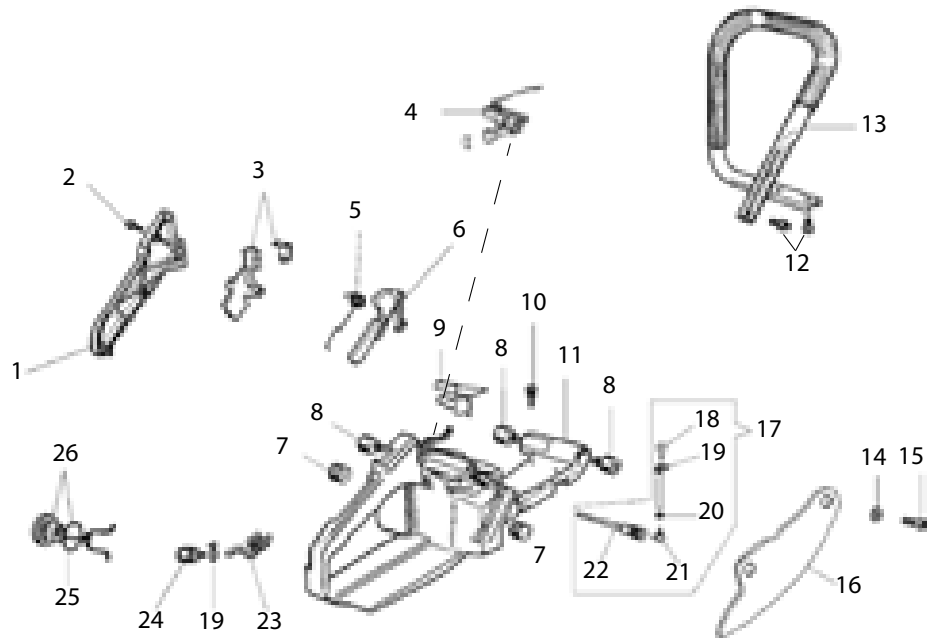

KEY	DESCRIPTION	TORQUE		LOCTITE® 242	PART NUMBER
		Nm	in-lbs.		
1	REAR HANDLE HALF				548392
2	SCREW	1.0	9		73976
3	THROTTLE LEVER				71749
4	THROTTLE LINKAGE ASSEMBLY				71750
5	TRIGGER LOCKOUT LEVER SPRING				73988
6	TRIGGER LOCKOUT LEVER				73987
7	SHOCK ABSORBER	4.0	35		505387
8	SHOCK ABSORBER WITH SCREW	4.0	35		505658
9	REAR HANDLE SHOCK ABSORBER				505425
10	BUMPER, SHOCK ABSORBER, FUEL TANK TOP				73270
11	FUEL TANK				548391
12	FRONT HANDLE BOLT	7.8	69	X	73983
13	FRONT HANDLE				548483
14	WASHER				73897
15	SCREW	8.8	78	X	73982
16	RUBBER WATER DEFLECTOR				505445
17	FUEL BREATHER COMPLETE				71748
18	FUEL BREATHER, REMOTE				71761
19	FUEL FILTER CLIP				71588
20	TUBE CLAMP				71760
21	BREATHER TUBE ELBOW				71759
22	BREATHER TUBE BODY				71751
23	FUEL LINE				73375
24	FUEL FILTER				73459
25	FUEL CAP O-RING				73448
26	FUEL CAP ASSEMBLY, WITH OUTER SEAL RIING				71739

FLYWHEEL ASSEMBLY

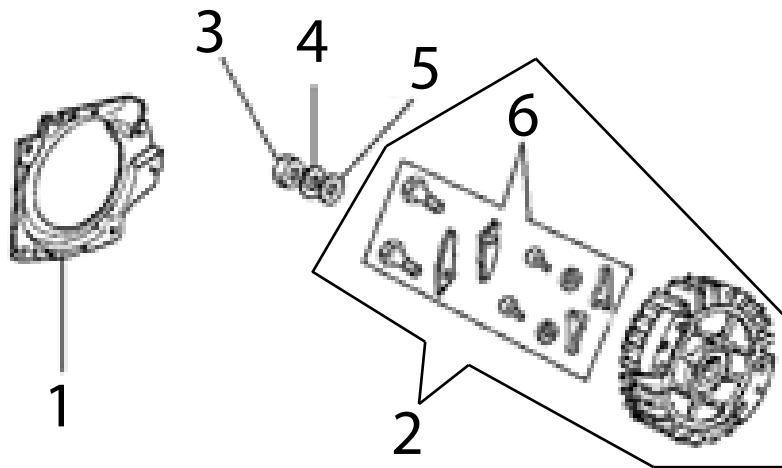

KEY	DESCRIPTION	TORQUE		LOCTITE® 242	PART NUMBER
		Nm	in-lbs.		
1	FLYWHEEL SHROUD				548514
2	FLYWHEEL				548515
3	NUT	24.5	217		73891
4	WASHER				73911
5	WASHER				73912
6	STARTER PAWL ASSEMBLY	6.8	60		508852

IGNITION ASSEMBLY

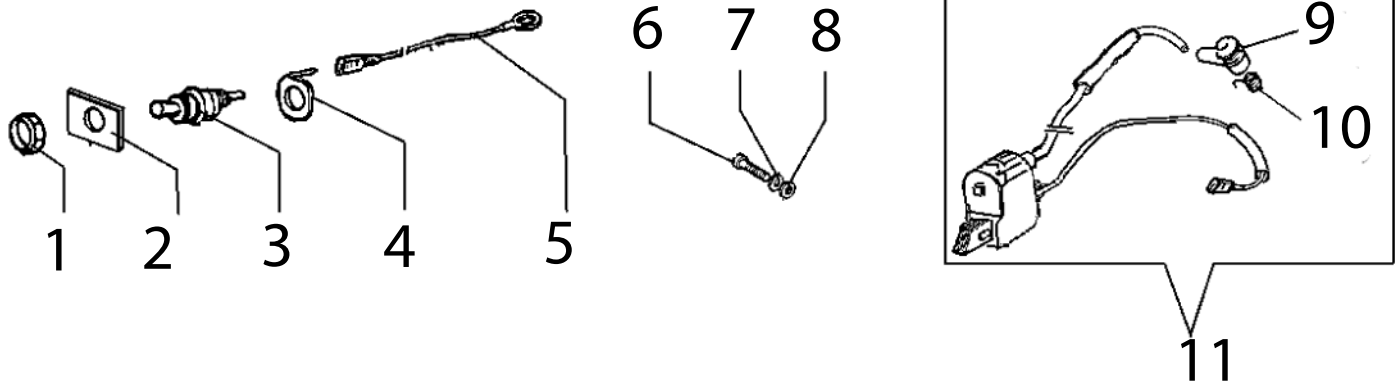

KEY	DESCRIPTION	TORQUE		LOCTITE® 242	PART NUMBER
		Nm	in-lbs.		
1	IGNITION TOGGLE SWITCH NUT				73239
2	IGNITION TOGGLE PLATE ON/OFF				73238
3	IGNITION TOGGLE SWITCH				73237
4	TOGGLE SWITCH CONNECTING PLATE				71449
5	IGNITION TOGGLE CABLE				73919
6	SCREW	2.9	26	X	73914
7	WASHER				73285
8	WASHER				73890
9	SPARK PLUG BOOT W/SPRING				73241
10	SPARK PLUG SPRING				73917
11	IGNITION COIL WITH SPARK PLUG LEAD & PRIMARY				505426

STARTER ASSEMBLY

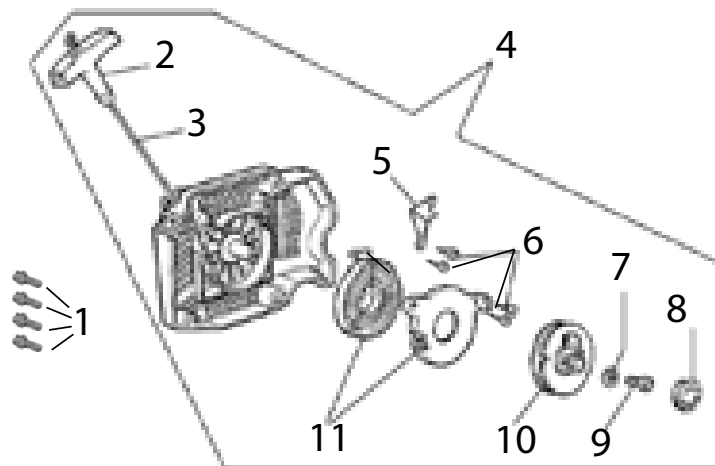

KEY	DESCRIPTION	TORQUE		LOCTITE® 242	PART NUMBER
		Nm	in-lbs.		
1	SCREW	6.8	60		73230
2	STARTER ROPE HANDLE				505514
3	STARTER ROPE				508854
4	STARTER ASSEMBLY				537666
5	STARTER CASE PLATE				71451
6	RECOIL HOUSING SCREW				505380
7	STARTER PULLEY WASHER				73905
8	STARTER ASSEMBLY CAP				508853
9	STARTER PULLEY SCREW	2.9	26	X	73907
10	STARTER ROPE PULLEY				508857
11	STARTER COIL SPRING & HOUSING				73909

AIR FILTER ASSEMBLY

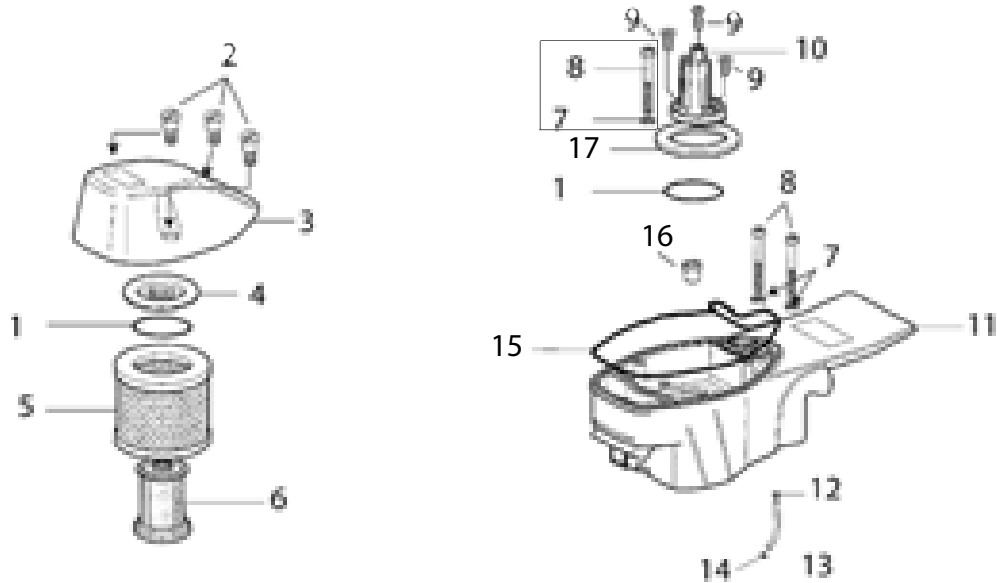

KEY	DESCRIPTION	TORQUE		LOCTITE® 242	PART NUMBER
		Nm	in-lbs.		
1	AIR FILTER O-RING				73331
2	FILTER COVER SCREW	4.0	35		73992
3	AIR FILTER COVER ASSEMBLY (WITH 3 SCREWS)				537661
4	AIR FILTER FLANGE				71758
5	AIR FILTER CANISTER, POLYESTER				71752
6	PREFILTER PLASTIC, SECONDARY FILTER				73336
7	WASHER				73897
8	CYLINDER COVER SCREW	4.0	35	X	505429
9	FILTER SUPPORT SCREW	4.9	43	X	505437
10	FILTER SUPPORT				73338
11	CYLINDER COVER				537660
12	O-RING				71472
13	COMPENSATOR TUBE				505382
14	TUBE CLAMP				71760
15	FILTER COVER GASKET				71756
16	BREATHER GROMMET				71763
17	FILTER CANISTER GASKET				73335

WATER DELIVERY SYSTEM

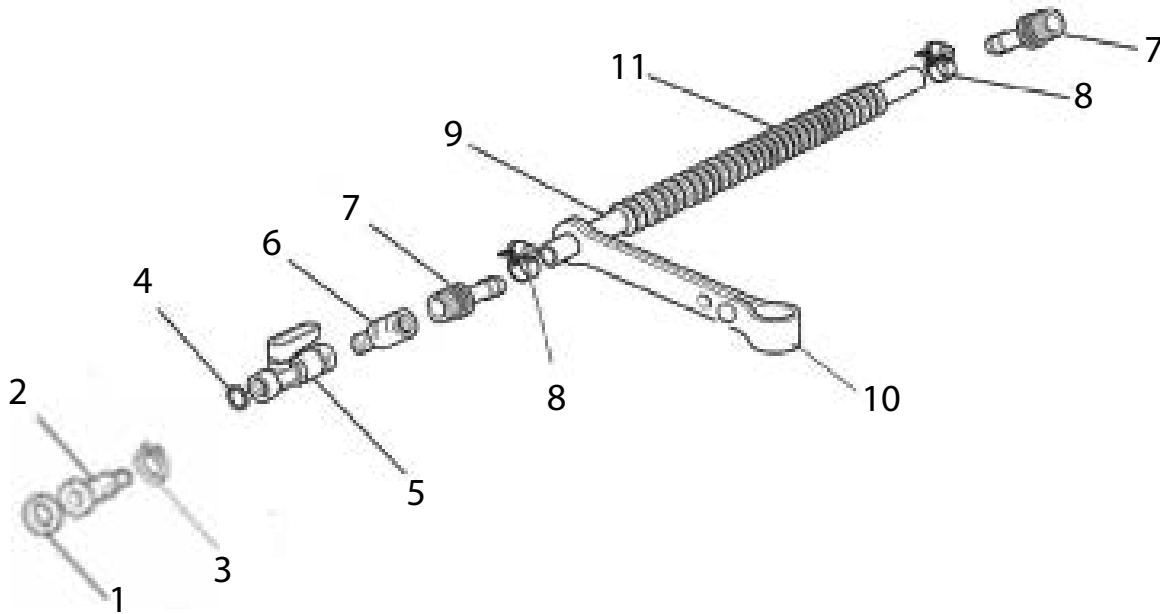

KEY	DESCRIPTION	TORQUE		LOCTITE® 242	PART NUMBER
		Nm	in-lbs.		
1	WATER HOSE GASKET				71469
2	FITTING				71467
3	RING NUT				71457
4	WATER HOSE O-RING				71468
5	WATER SHUT-OFF VALVE				71458
6	FITTING				71466
7	FITTING				71454
8	HOSE CLAMP				71465
9	WATER HOSE				509488
10	HOSE HANGER				71461
11	WATER HOSE COVER				71464

SIDE COVER ASSEMBLY

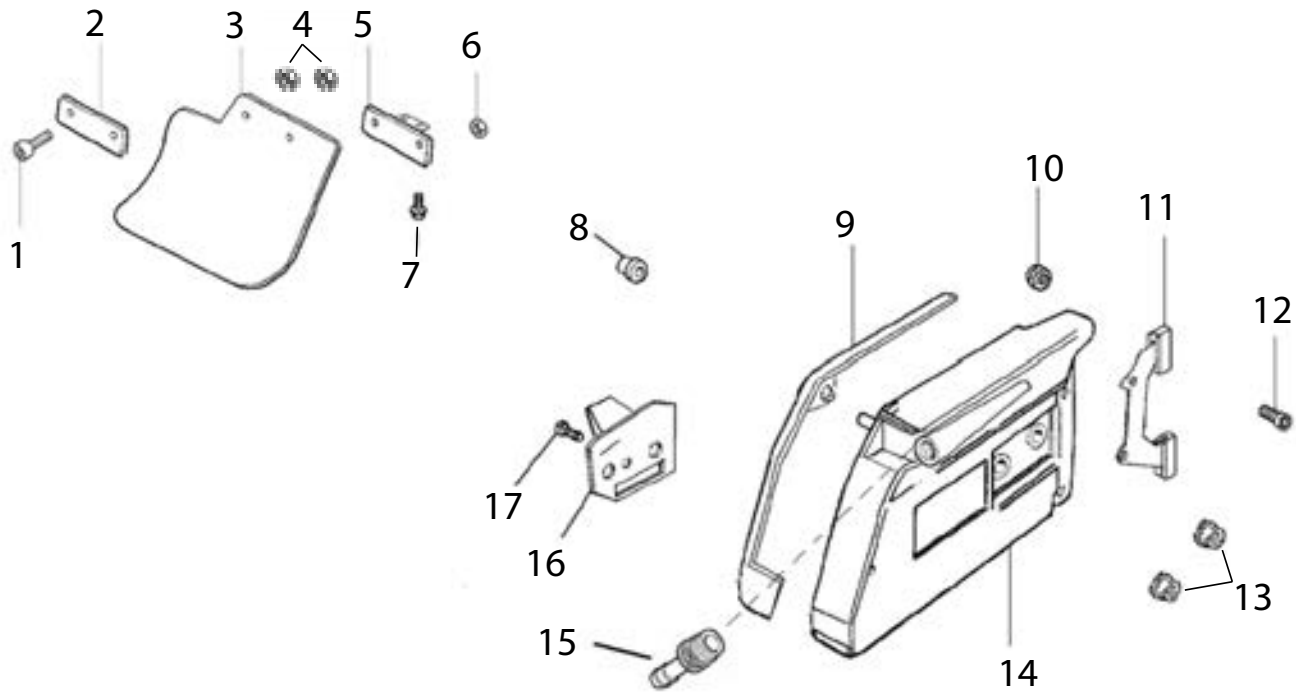

KEY	DESCRIPTION	TORQUE		LOCTITE® 242	PART NUMBER
		Nm	in-lbs.		
1	GUARD FLAP SCREW				71479
2	GUARD FLAP MOUNTING BRACKET, FRONT				505491
3	GUARD FLAP NUT				505492
5	GUARD FLAP MOUNTING BRACKET, BACK				505490
6	GUARD FLAP NUT				505468
7	BOLT				73983
8	RUBBER BUMPER, COVER				73310
9	SIDE COVER GASKET				505417
10	MOUNTING NUT				509852
11	RUBBER WALLWALKER				505493
12	SCREW	4.9	43		73982
13	SIDE COVER NUT	27.5	243		73958
14	SIDE COVER				537662
15	FITTING			X	71454
16	SIDE COVER PLATE				505419
17	SCREW				71487

CARBURETOR REPAIR KIT

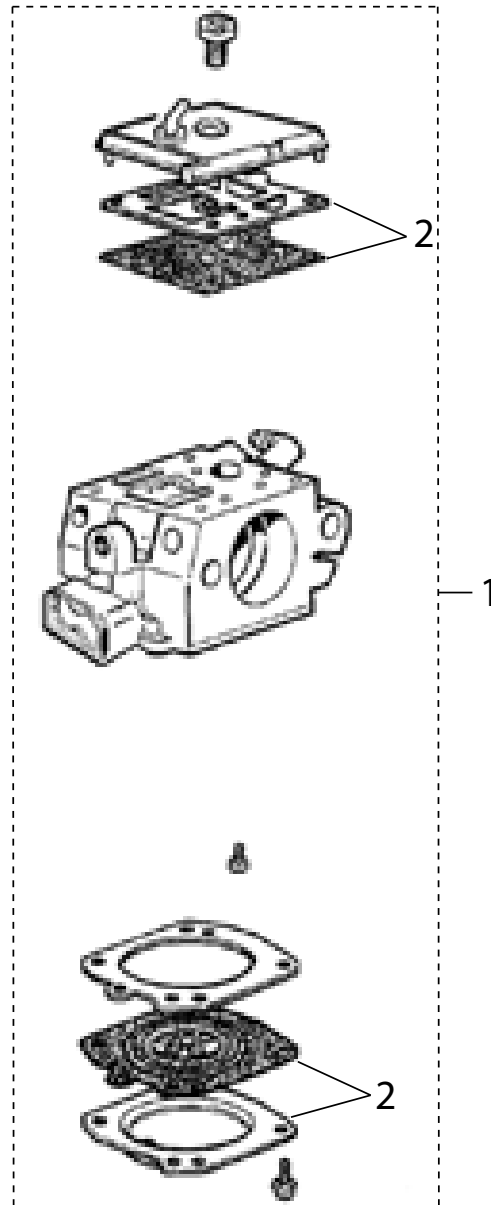

KEY	DESCRIPTION	TORQUE		LOCTITE® 242	PART NUMBER
		Nm	in-lbs.		
1	CARBURETOR REPAIR KIT				548394
2	CARBURETOR WALBRO HDA-225				548393

5 This section covers the disassembly, inspection, and assembly of the air induction system.

5.1 Loosen the air filter cover screws and remove air filter cover.



5.2 Remove air filter from cover.

- A Inspect air filter.
- B Replace if necessary (P/N 71752).



5.3 Remove secondary filter from air filter mount.

- A Clean secondary filter with cleaning solution and a nylon brush.
- B Let dry and reinstall.



- 5.4 Inspect air filter cover gasket.
- A Replace if permanently depressed or hard due to slurry.
- 5.5 Inspect filter cannister gasket.
- A Clean.
 - B Replace if necessary.



- 5.6 Secure air filter mount screws (3) using Loctite® 242.



6 This section covers the removal, inspection, and installation of the spark plug.

6.1 Remove the spark boot taking care not to pry or damage the wire.

6.2 Clean area around the spark plug to prevent debris from entering the cylinder.

6.3 Remove the spark plug.

6.4 Inspect the spark plug for proper size, gap and condition.

A If dirty, clean with a wire brush as shown.



6.5 Gap if necessary to 0.02" (0.5 mm).

NOTE: If the spark plug must be replaced refer to the Spark Plug Reference Guide on page 81 to select the correct replacement plug.

6.6 Assemble in the reverse order.

- A Make sure the plug boot is seated completely.



7 This section covers clutch removal, rim sprocket removal, inspection, and assembly. Refer to sections 5 and 6 if needed.

7.1 Insert piston stop tool into spark plug hole.



7.2 Pull starter handle until piston stops against tool.



7.3 Remove clutch.

⚠ Left hand threads – rotate clockwise to loosen.

NOTE: If an impact wrench is available steps 7.1 and 7.2 do not have to be performed.

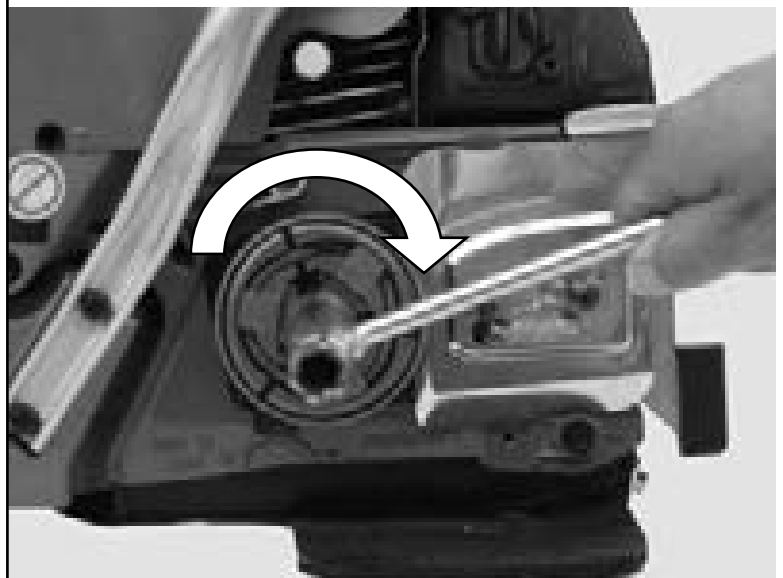

7.4 Remove all drive components.



7.5 Inspect the clutch shoes for wear.
A Replace if the shoe has less than 0.04" (1 mm) of material, as shown.

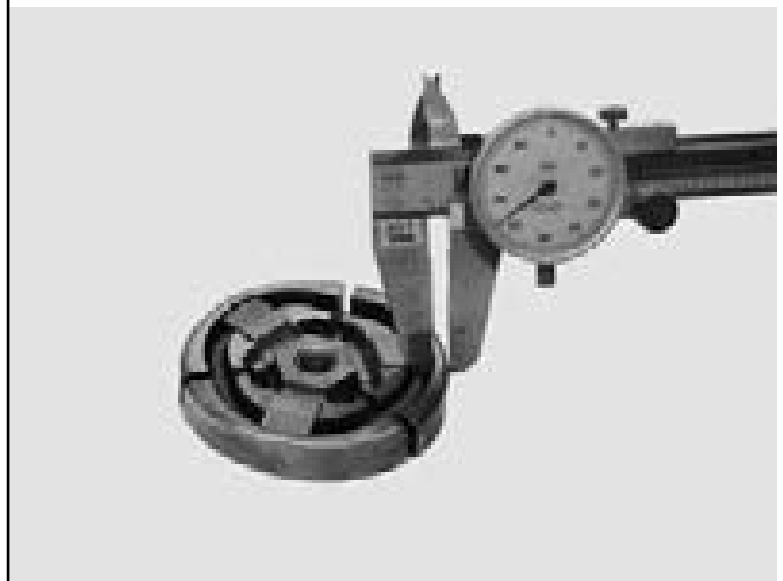

7.6 Inspect spring for cracks.



7.7 Assemble clutch.

A Insert top edge of clutch shoe over spring as shown.



7.8 Snap clutch shoe into place.

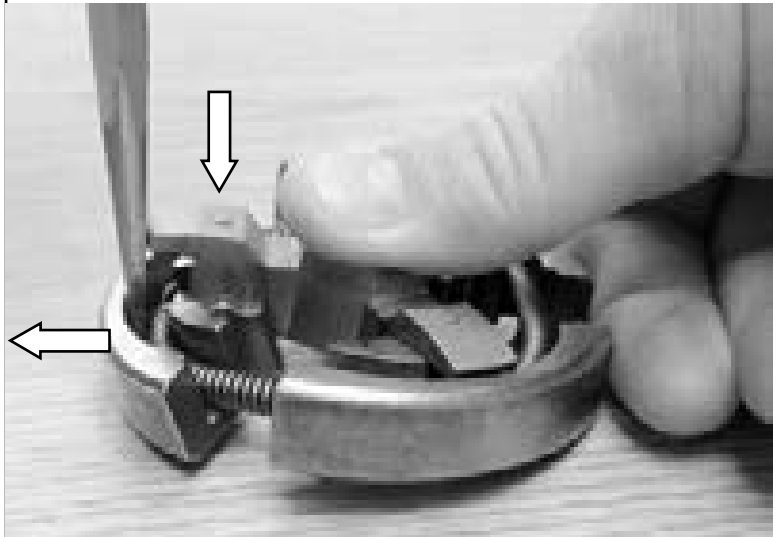

7.9 Inspect the rim sprocket for wear.

A Replace if the rim sprocket teeth are worn to points, as shown on right.



7.10 Clean and assemble.

- A Clean all parts in solvent.
- B Grease needle bearing (ICS® P/N 505378) with a waterproof grease
- C Assemble clutch spacer washer, bearing, clutch cup with rim sprocket, and inside clutch spacer washer.



7.11 Install clutch.

- A Torque to 295 in-lbs (33.3 Nm)
- ⚠ Left hand threads

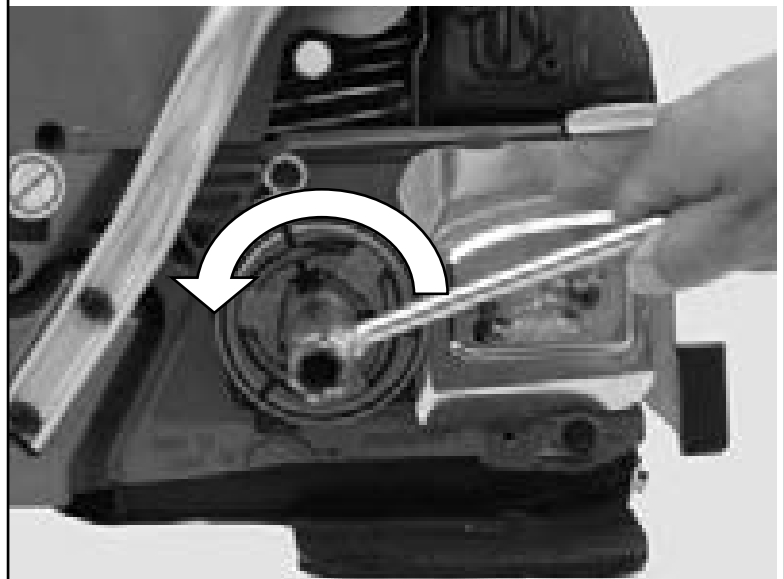

8 This section covers the removal of the starter cover, replacement of the starter rope, and replacement of the recoil spring.

8.1 Remove starter cover screws (4).

8.2 Remove starter cover assembly from saw.

8.3 Remove starter cord shield screws.

8.4 Relieve spring tension.

- A Pull 4-6" (10-15 cm) of rope out.
- B Line rope up with notch on pulley.
- C To release pulley, slowly rotate pulley counterclockwise until spring pressure is released. Use thumb as a brake.

8.5 Remove rubber screw seal.

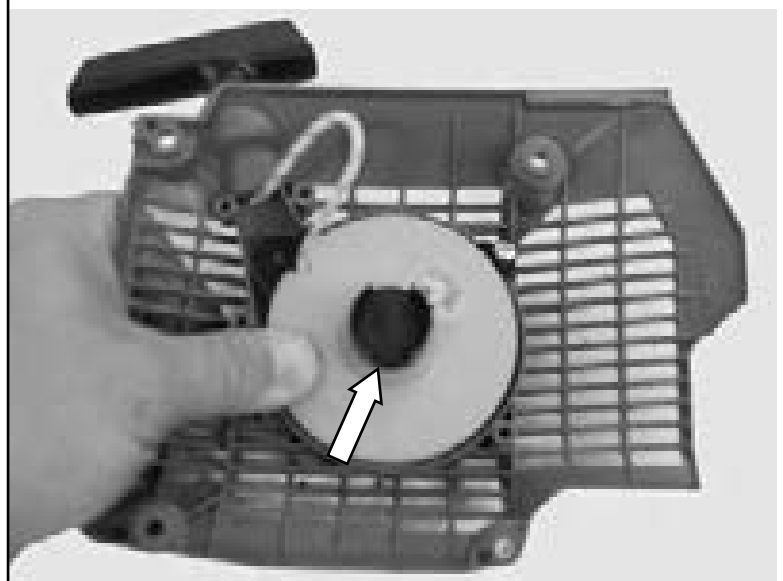
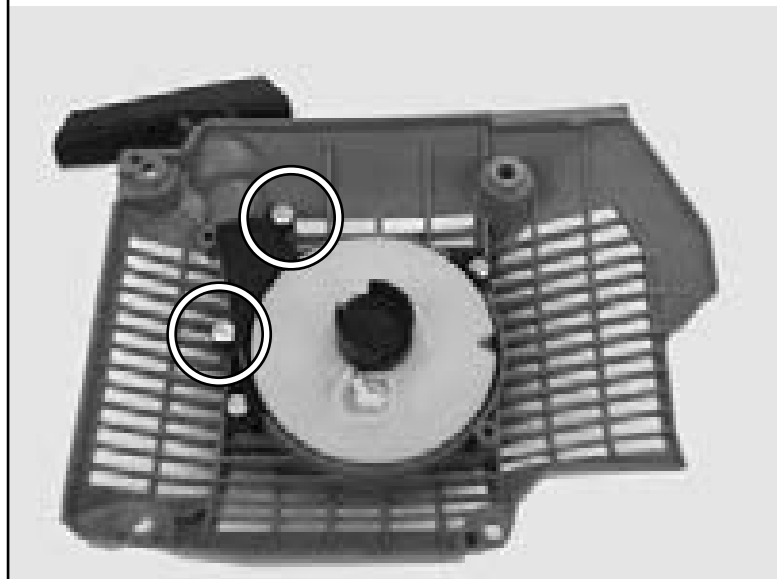
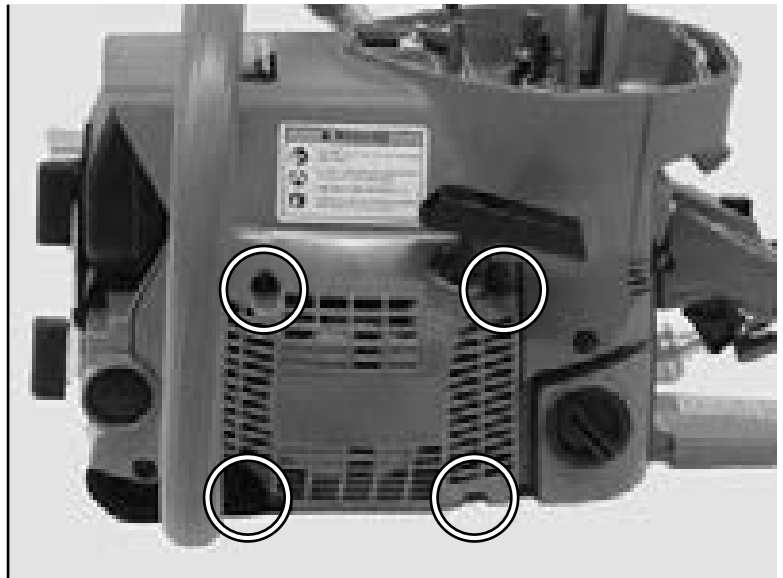

8.6 Remove starter pulley.

A Remove pulley screw.

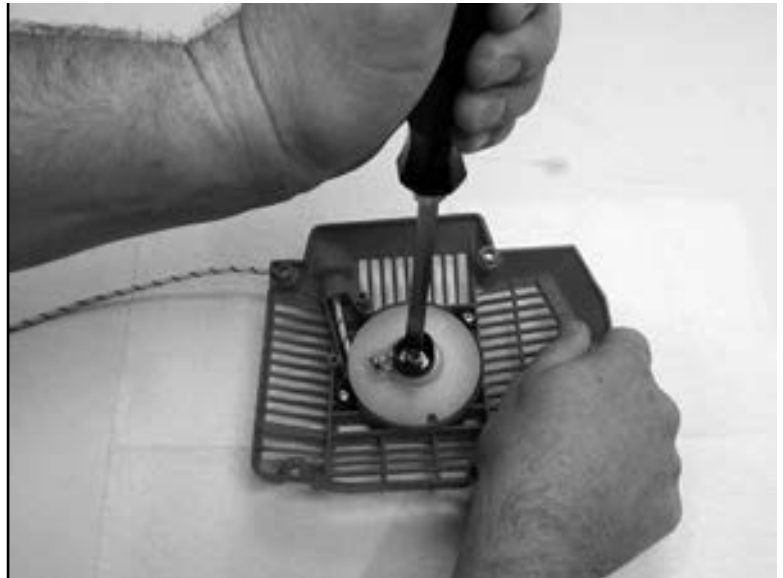

8.7 Inspect coil spring.

A Replace if spring hook is damaged. Attempting to re-bend the spring hook may cause the hook to break off.

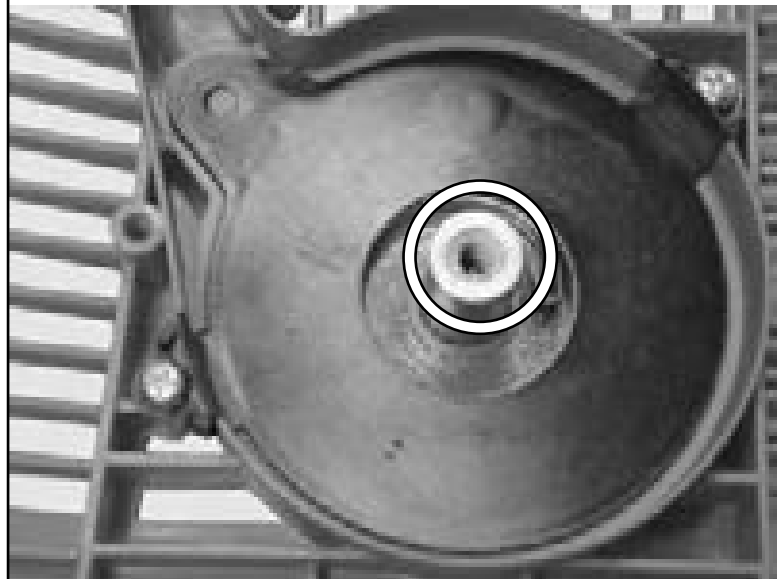

B Carefully remove coil spring and housing to prevent spring from unwinding.

8.8 Lubricate with lightweight oil.

8.9 Replace parts carefully.

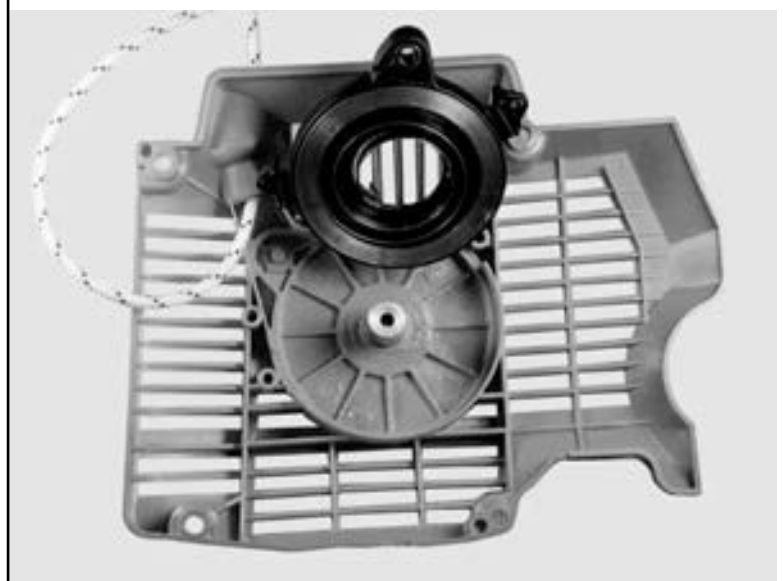

- 8.10 Inspect pulley spring catch.
- A Clean with cleaning solution.
 - B Replace if worn or broken.

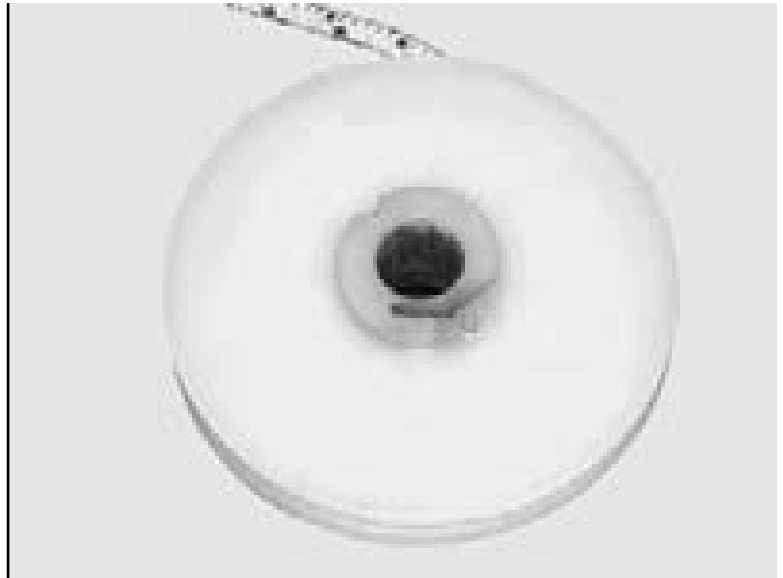

- 8.11 Install starter rope and tie knot.

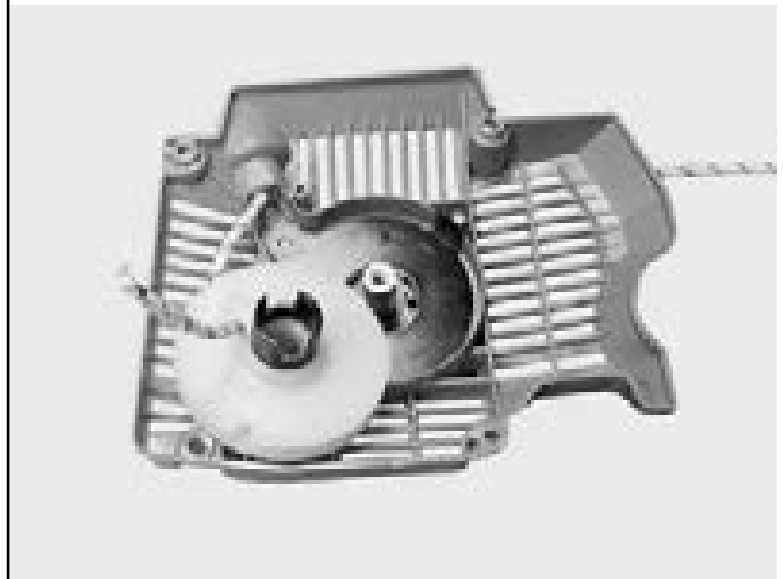

- 8.12 Knot tying instructions:
- A Make a loop at the end of the pulley rope with the end of the rope crossing on top of the tail.
 - B Bring the end of the rope through the loop, creating a single loose knot.
 - C Pull the end of the rope down and in front of the tail.
 - D Send the end through the loop a second time, creating a double knot; cinch tight.

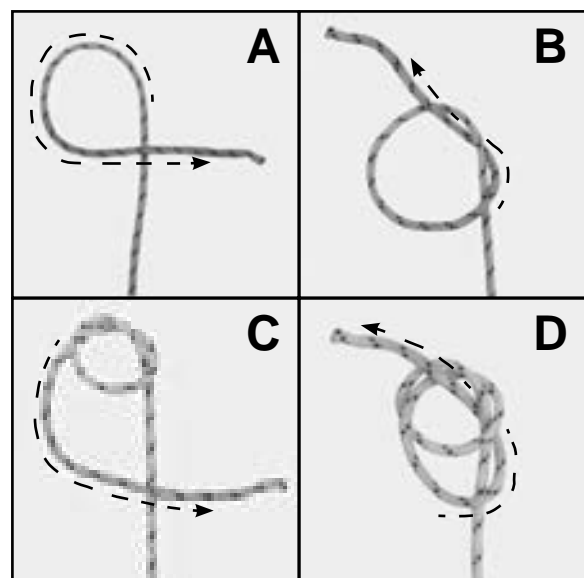

8.13 Install pulley.

- A Wind rope onto pulley clockwise leaving 4-6"(10 - 25 cm) out.
- B Make sure that the pulley spring catch is in the spring hook.

8.14 Install center screw.

- A Use Loctite® 242.
- B Torque to 26 in-lbs. (2.9 Nm).

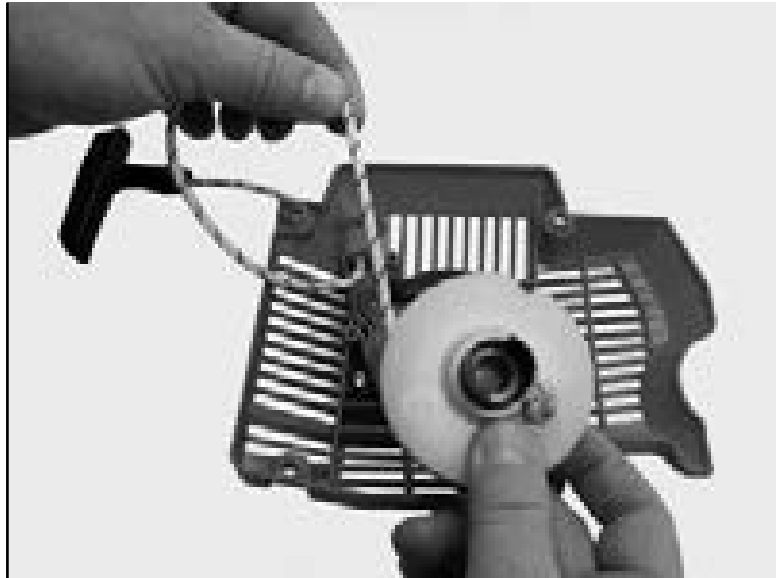

8.15 Wind the recoil spring.

- A Line rope up with notch on pulley.
- B Rotate the pulley with the rope clockwise 5 times.
- C Untangle rope and release.

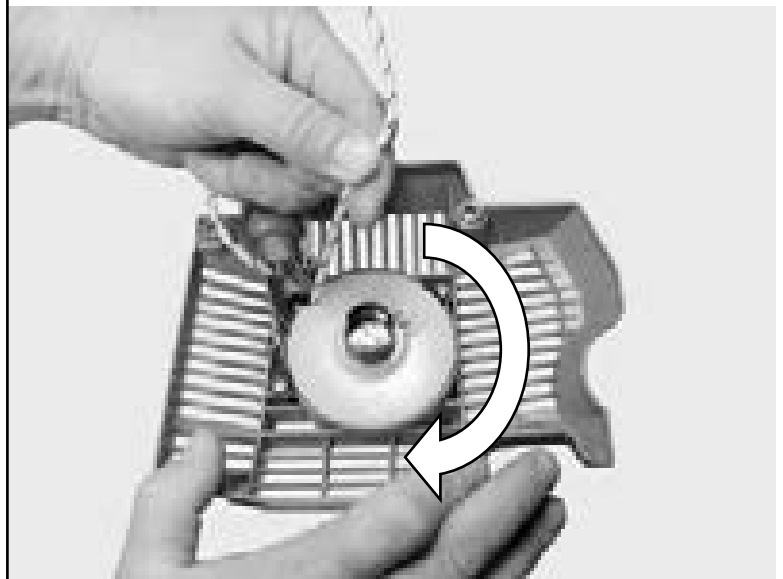

8.16 Assemble starter cord shield.

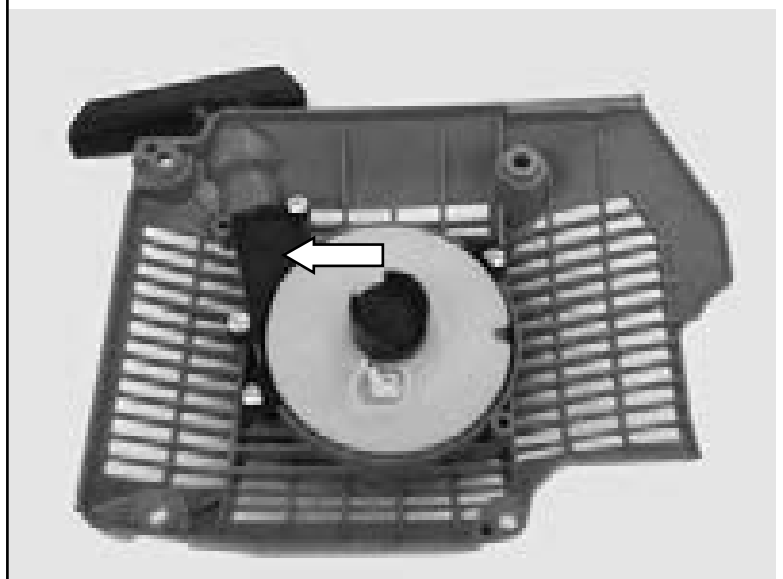

- 8.17 Remove starter pawl screws, pawls, spring, and plain washer.

NOTE:

Piston stop tool may be required to remove the starter pawl screws.

- 8.18 Inspect and clean pawl components.

- A Inspect the components.
Replace if necessary.
- B Clean the components with a brush and solvent.

- 8.19 Assemble components.

- A Make sure the spring is in the correct position.
- B Use Loctite® 242 on the pawl screws.
- C Torque to 60 in-lbs. (6.8 Nm).

- 8.20 Install starter cover.

- A Pull out cord 4-6" (10 - 15 cm).
- B Slowly release while placing cover to allow pawls to engage.

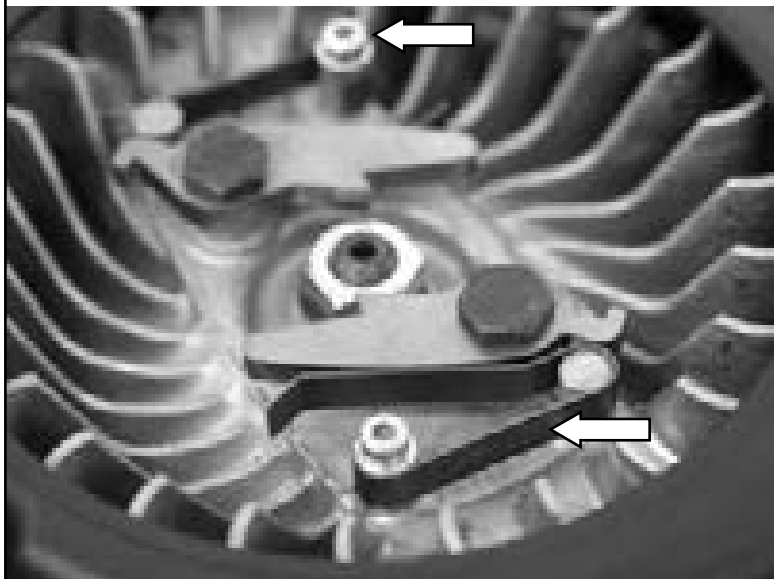
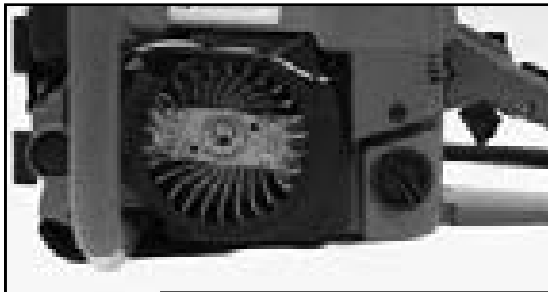

- 8.21 Install starter cover screws (4).
- A Use Loctite® 242.
 - B Torque to 60 in-lbs. (6.8 Nm).

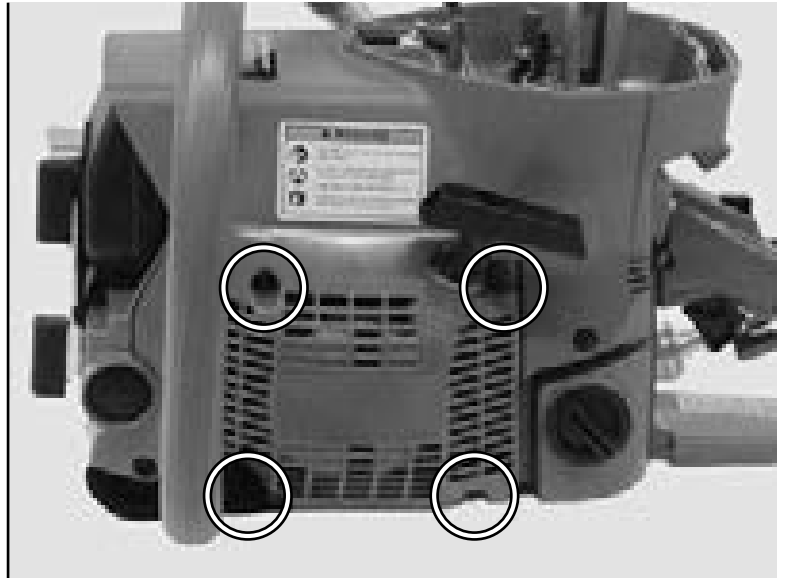

9 This section covers the removal, inspection, and assembly of the rubber padded WallWalker® and guard flap.

9.1 Inspect bumpers.

A Replace if worn.

9.2 Remove side cover assembly.

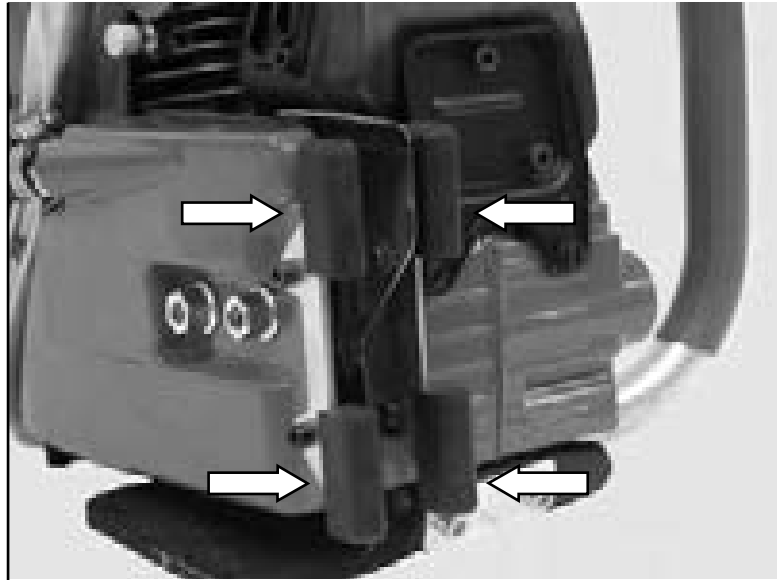

9.3 Remove cover plate.



9.4 Remove crankcase screws (2) and wave washers.



9.5 Remove and inspect guard flap.

- A Replace the flap if it is torn or damaged in any way.



9.6 Remove guard flap screws and washers.



9.7 Reassemble in the reverse order.

- A Install crankcase screws and wave washers.
- B Use Loctite® 242.
- C Torque to 70 in-lbs. (7.9 Nm).



10 This section covers the disassembly and assembly of the cylinder cover. Removal of the air intake components and front handle is necessary. Refer to sections 5 and 17 if needed.

10.1 Remove the air filter mount screws.

NOTE: May require heat to remove screws.

10.2 Remove the cylinder cover screws (3).

10.3 Remove spark plug boot from cylinder cover taking care not to pry or damage the wire.

10.4 Remove fuel tank breather cap and clamp.

10.5 Partially remove intake manifold from cylinder cover.

10.6 Remove cylinder cover.

- A Pull up on front.
- B Push intake manifold through hole.
- C Make sure throttle linkage is disengaged from cylinder cover.
- D Guide fuel breather tube and compensator tube through cylinder cover.



- 10.7 Remove stop switch leads.
- 10.8 Inspect cylinder cover for damage.
 - A Replace if necessary.

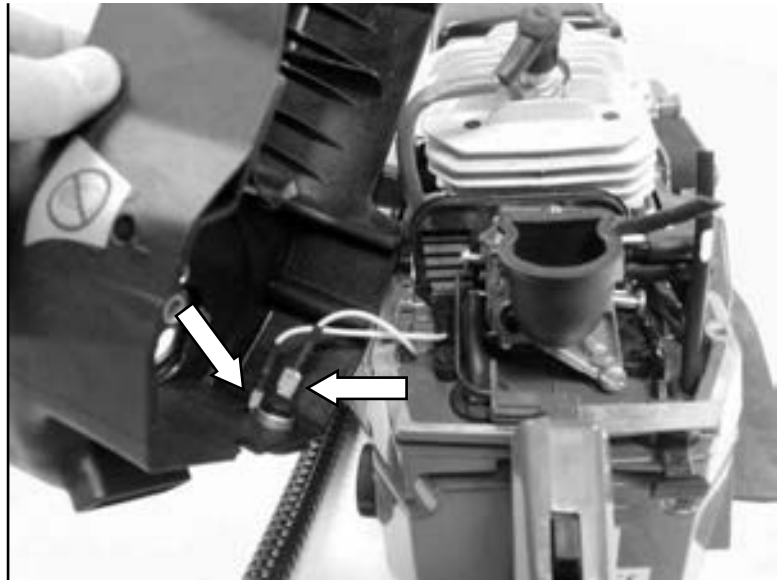

- 10.9 Check filter cover gasket.
 - A Replace if necessary.

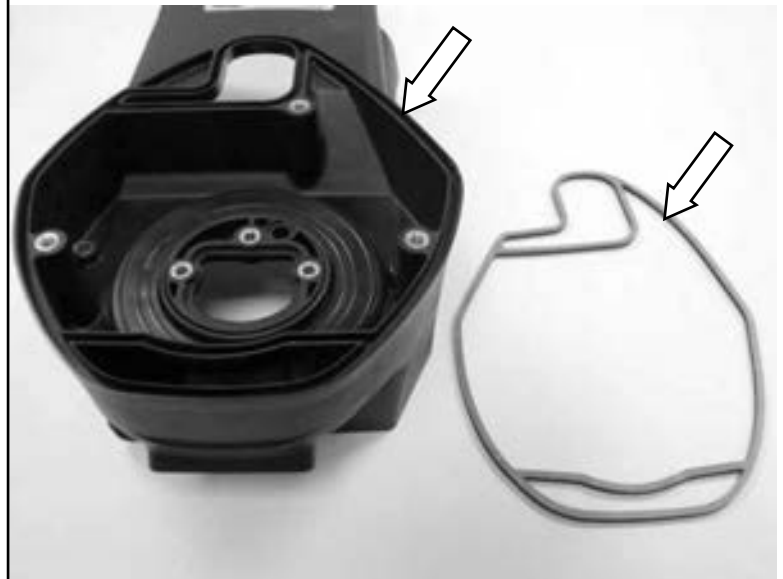

- 10.10 Check cylinder cover water seal.
 - A Replace if necessary.

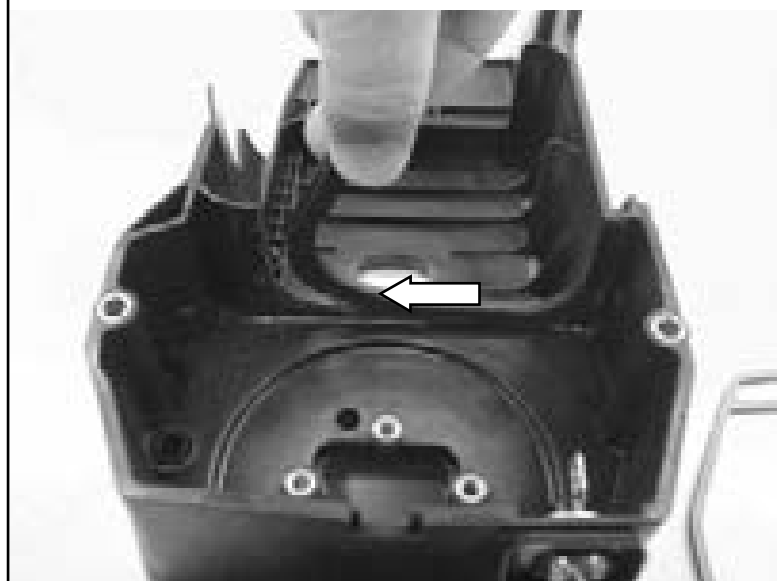

10.11 Assemble in reverse order.

- A Reassemble stop switch leads.

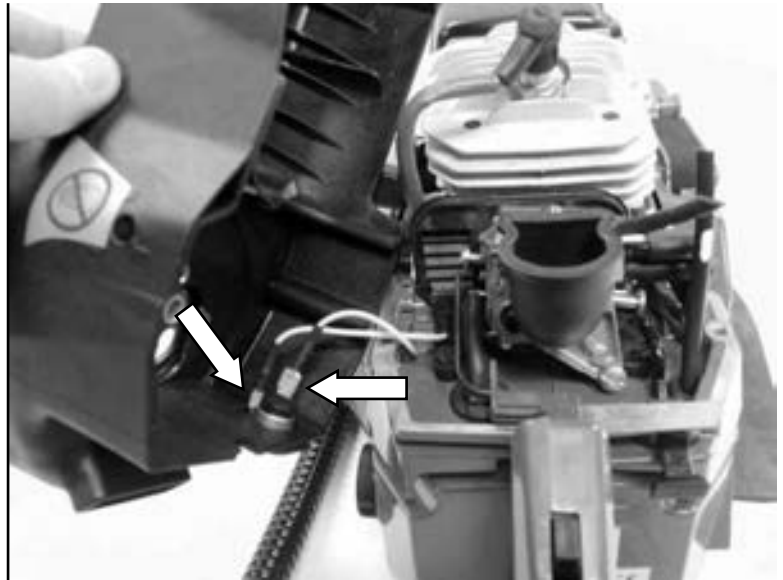

10.12 Make sure carburetor screw boot is in place.



10.13 Install cylinder cover.

- A Pull spark plug lead into slot in cylinder cover.
- B Lubricate compensating tube (1) and fuel tank breather tube (2) with soapy water, guide through cylinder cover (Install compensating tube first).

NOTE: Be careful to not pull tubes away from their point of connection. Approximately 3/4" of tube should protrude from cylinder cover.

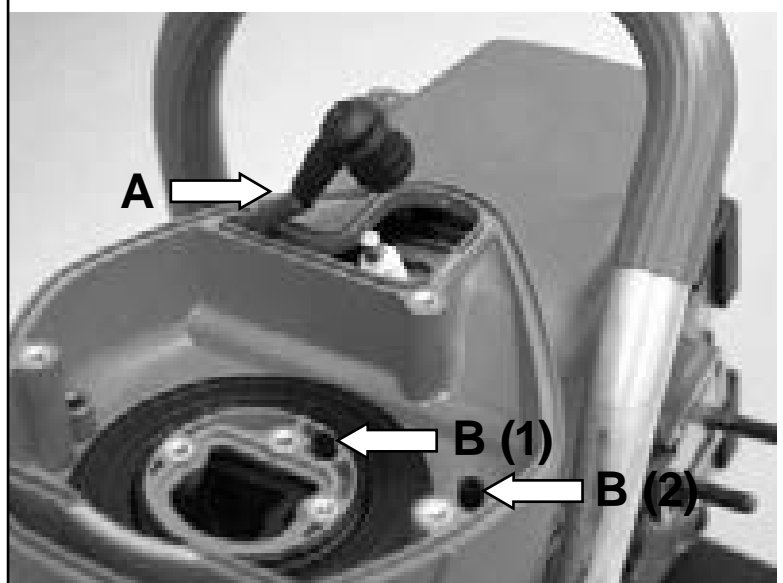

- C Push the cylinder cover down on the crankcase, guide intake manifold into cylinder cover.
- D Align throttle linkage with cylinder cover and crankcase.
- E Install the cylinder cover screws. Use Loctite® 242. Torque to 35 in-lbs. (4.0 Nm).

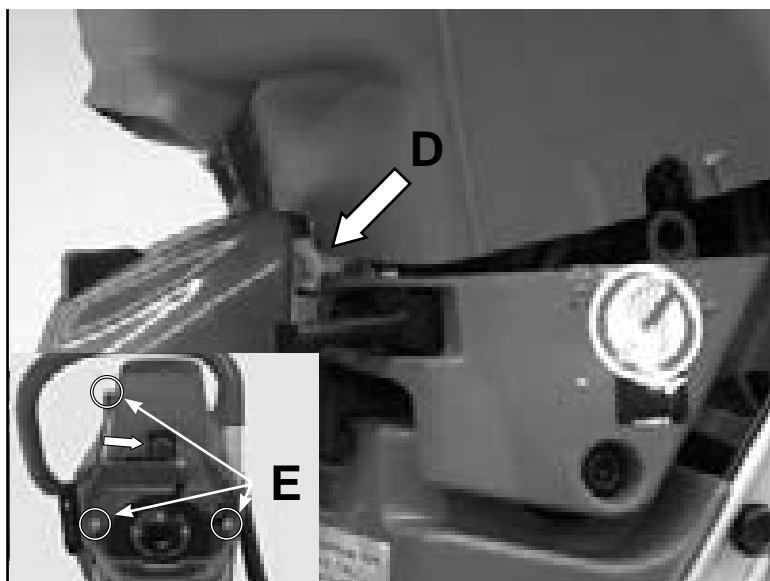

10.14 Install air filter mount.

- A Guide carburetor compensating tube through air filter mount. Make sure manifold sits flat over lip on cylinder cover (see section 10.5).
- B Install air filter mount screws (3) using Loctite® 242.
- C Torque to 43 in-lbs. (4.9 Nm).



10.15 Install air filters and cover.

- A Install pre-filter.
- B Install clean air filter.
- C Install air filter flange and tighten.
- D Install air filter cover and tighten.



11 This section covers the disassembly, inspection, and assembly of the muffler. Removal of the bumpers and cylinder cover is necessary. Refer to sections 9 and 10 if necessary.

11.1 Remove muffler support screws.

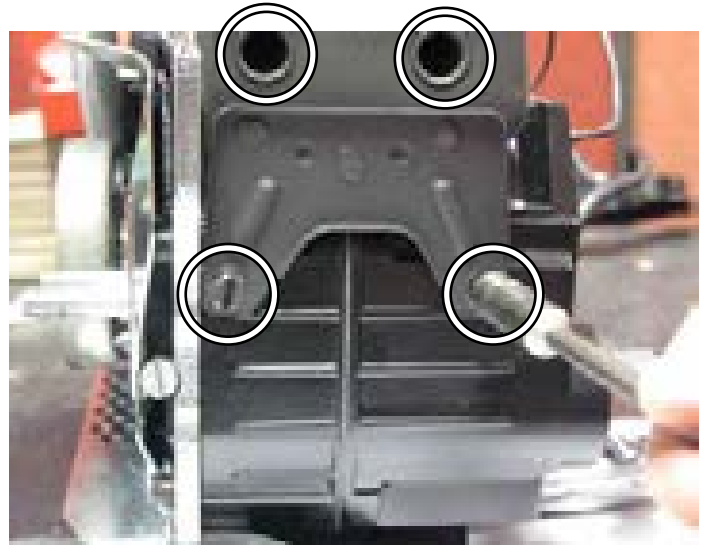

11.2 Remove muffler screws located inside the muffler.

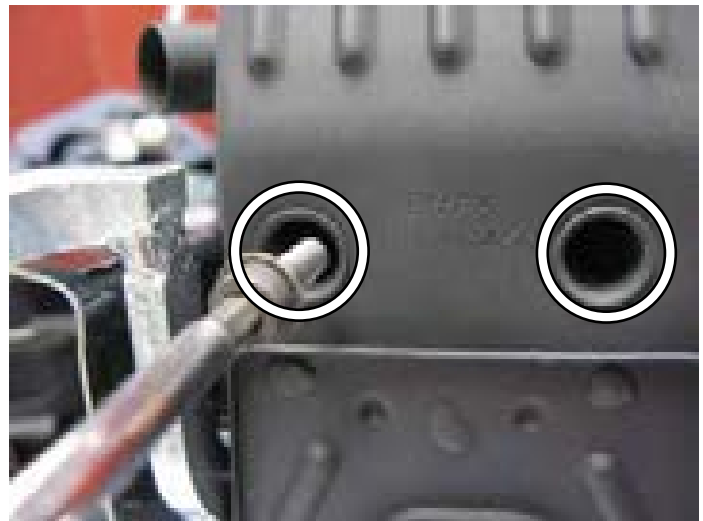

11.3 Remove muffler and heat shield gasket.

- Replace any damaged components.



11.4 Install muffler.

- Insert muffler screws (2) into muffler.
- Hold muffler screws in place with heat shield gasket.
- Thread muffler screws into cylinder with Loctite®242. Torque to 78 in-lbs. (8.8 Nm).

**11.5 Install bottom (2) muffler support screws with Loctite®242.**

- Torque top screws to 78 in-lbs. (8.8 Nm).
- Torque bottom screws to 52 in-lbs. (5.8 Nm).

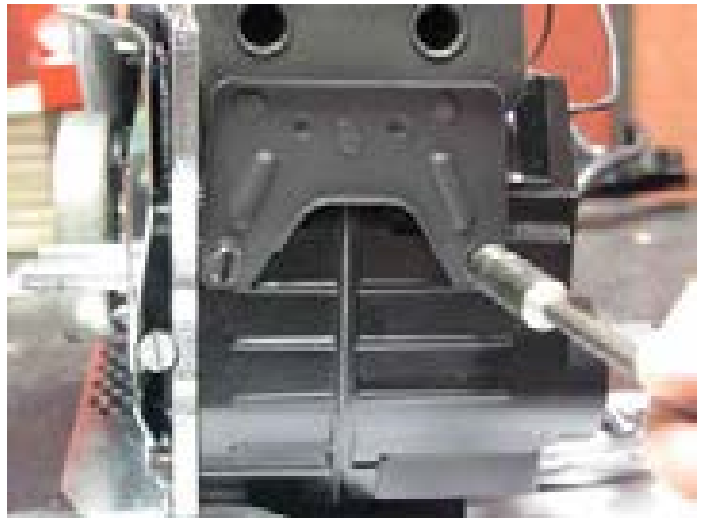

- 12** This section covers the removal and installation of the carburetor. Removal of the air intake components and cylinder cover is required. Please refer to sections 5 and 10 or 11 if necessary. Carburetor tuning is covered in section 22.

NOTE: All saws are equipped with carburetor model # HDA-225.

- 12.1** Remove throttle linkage.
- A Push trigger end out of rear handle.
 - B Pivot linkage around.
 - C Remove carburetor end of linkage from throttle rod tab on carburetor.
- 12.2** Remove fuel line from carburetor and support bracker.
- 12.3** Remove carburetor support bracket.
- A Remove carburetor support screw (1) with #4 Torx or straight blade screwdriver.
 - B Remove carburetor body screws (2).

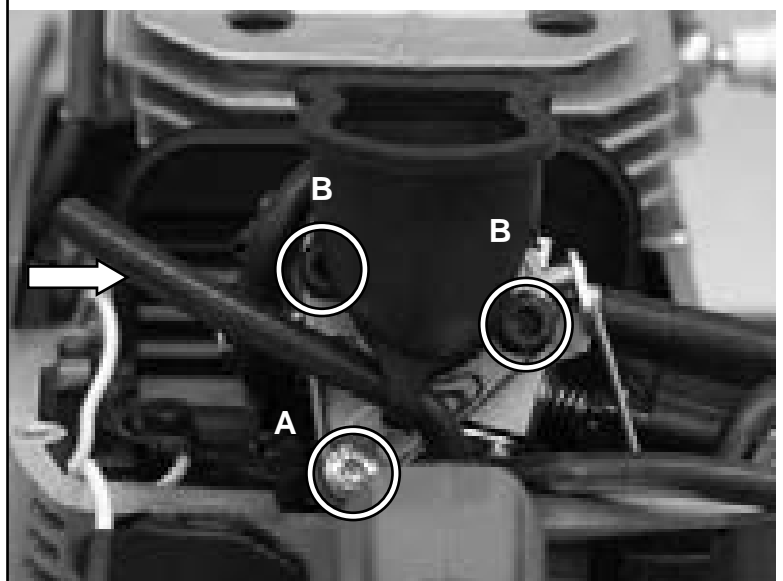
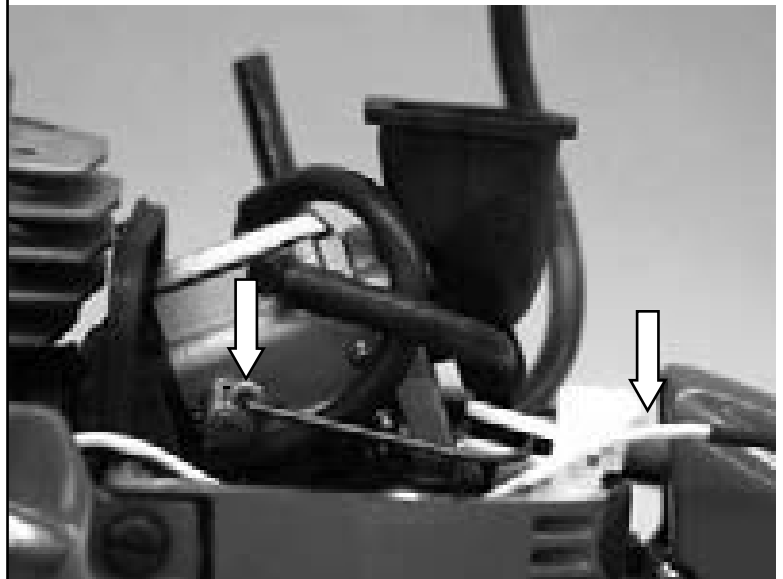

12.4 Remove carburetor.

- A Remove pulse tube.
- B Remove carburetor jet cover.
- C Remove carburetor from choke linkage.

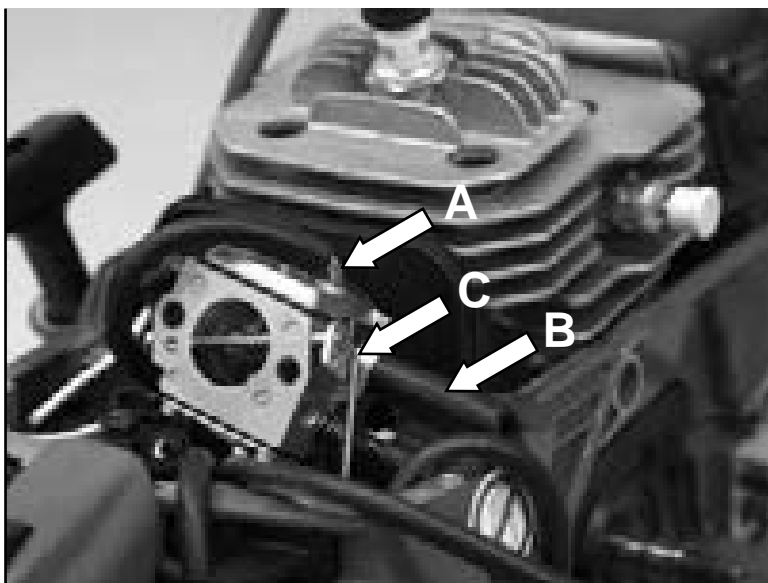

12.5 Assemble in the reverse order.

- A Torque carburetor body screws to 43 in-lbs. (4.9 Nm).
- B Torque supporter screw with Loctite® 242 to 43 in-lbs. (4.9 Nm).



- 13** This section covers the disassembly, inspection and assembly of the cylinder, piston and related components. Removal of several component groups is required. Refer to sections 5, 6, 10, and 12 if necessary.

NOTE: When replacing the 660GC cylinder and piston it is necessary to tune the carburetor prior to returning the saw to service (see section 22).

- 13.1 Remove carburetor base screws (3).
- A Remove carburetor base bracket from rear manifold.
 - B Remove carburetor base bracket from pulse tube.

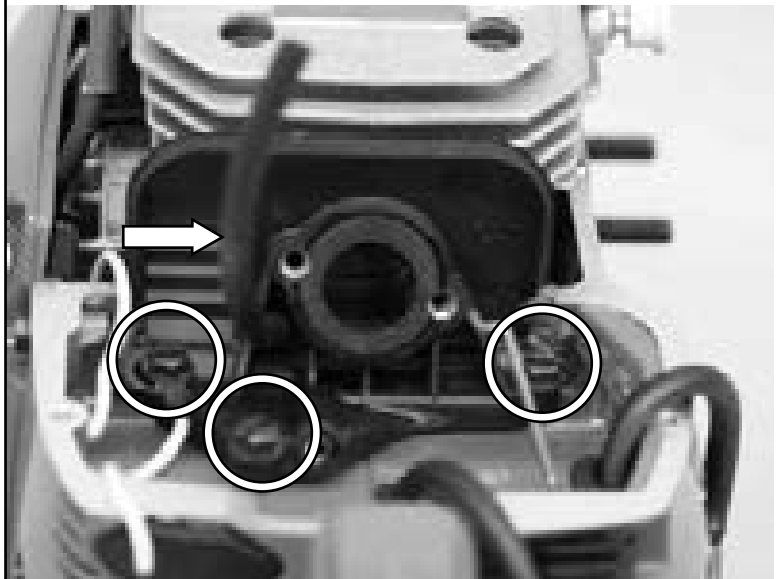

- 13.2 Remove pulse tube and protective spring from cylinder base.

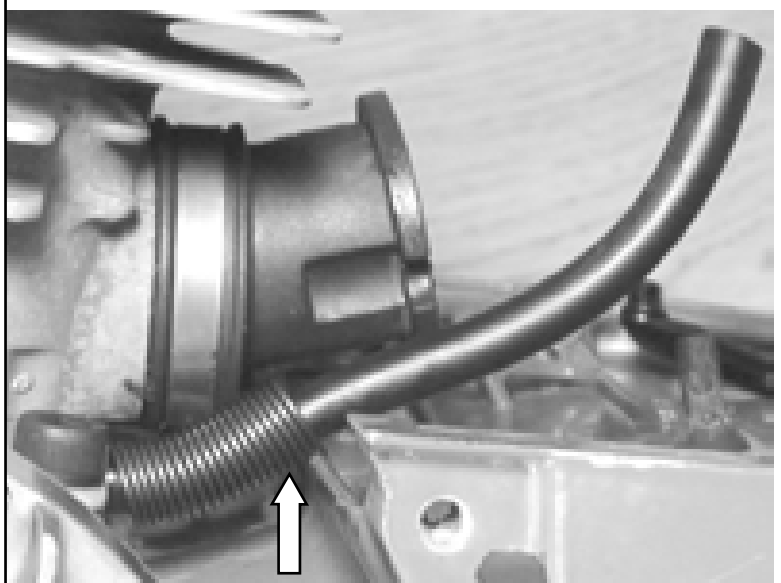

- 13.3 Remove rear manifold clamp.
- 13.4 Remove rear manifold from cylinder.
 - A Inspect for holes and tears.

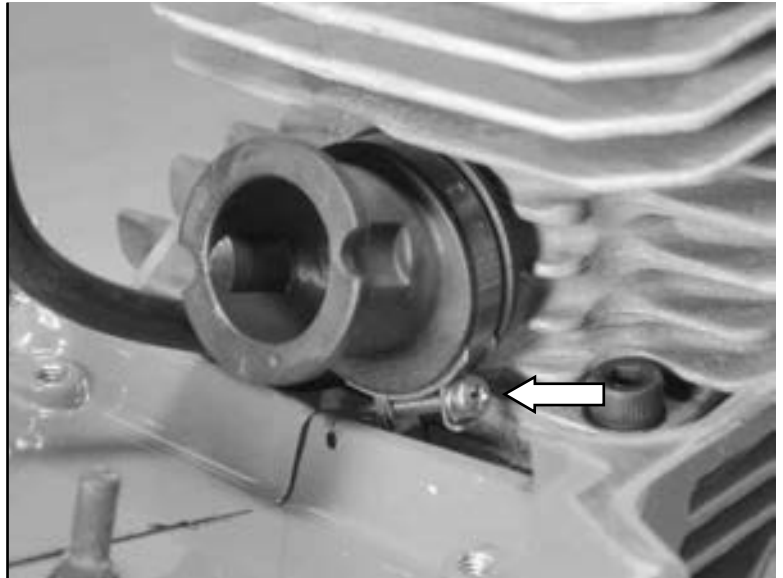

- 13.5 Remove cylinder screws (4) and wave washers (2 on front and 2 on back)

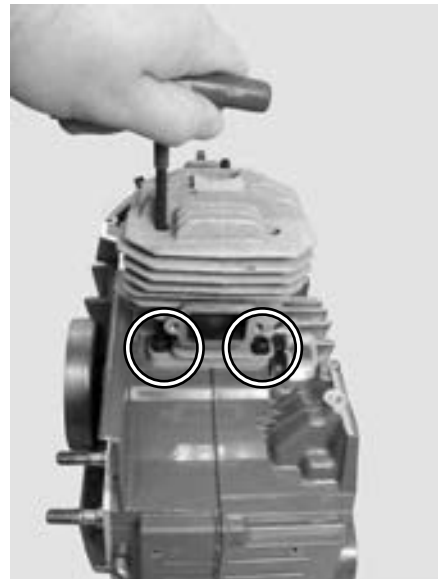

- 13.6 Remove cylinder.
 - A Remove cylinder gasket and clean case.

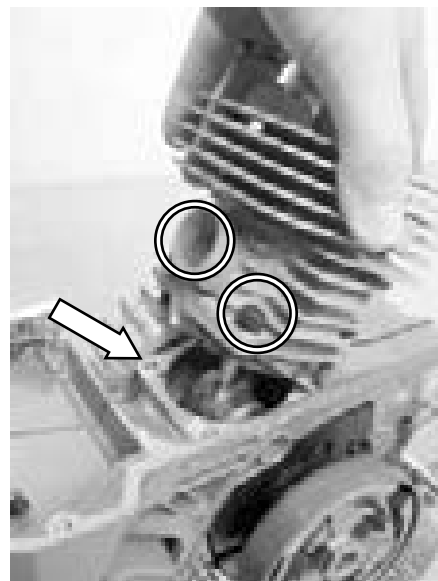

13.7 Remove wrist pin retaining clips (2).



13.8 Press wrist pin out with an 8 mm deep socket.

13.9 Remove piston and inspect.
Replace if damaged.

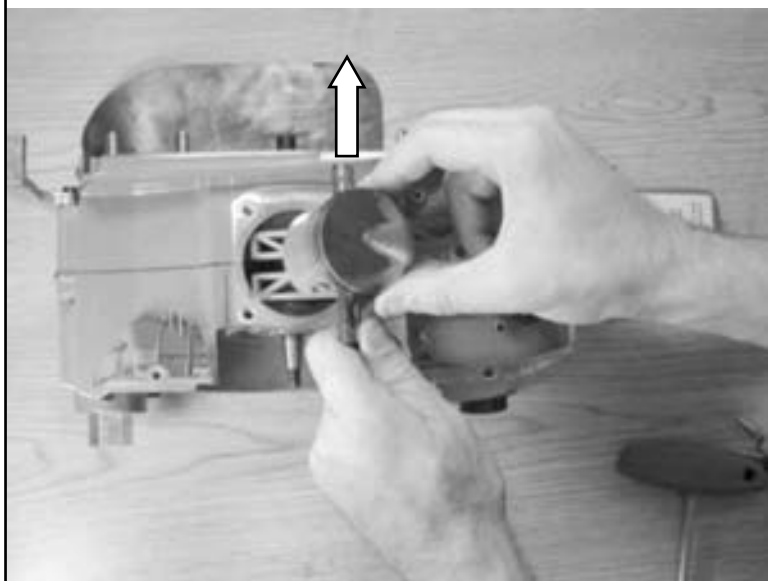

13.10 Remove wrist pin bearing.



13.11 Assemble cylinder gasket.

- A Oil gasket with ICS® 2-stroke engine oil.
- B Install and align holes and notch.

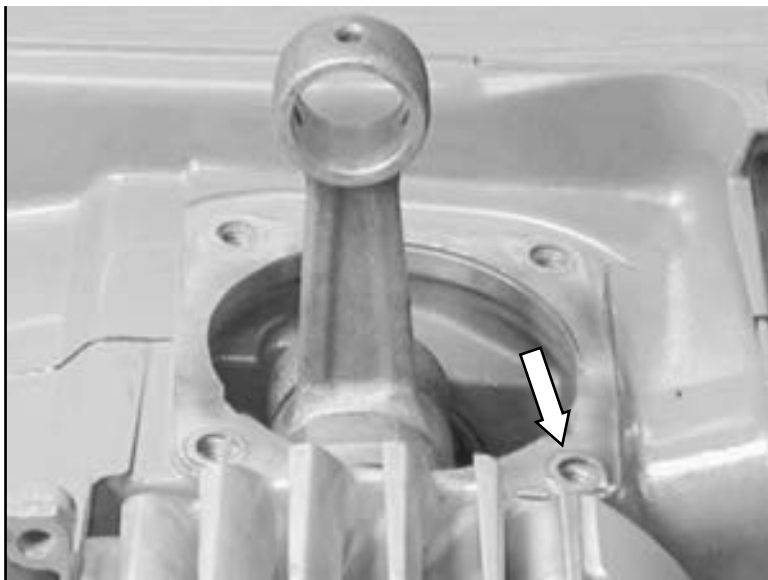

13.12 Install wrist pin bearing in rod.

- A Oil bearing with ICS® 2-stroke engine oil.



13.13 Install rings.

- A Install bottom ring first. Installing bottom ring over the top ring may cause the ring to break.



13.14 Ring orientation.

NOTE: Make sure both piston ring end gaps are correctly oriented over their locating pins in the piston ring grooves.

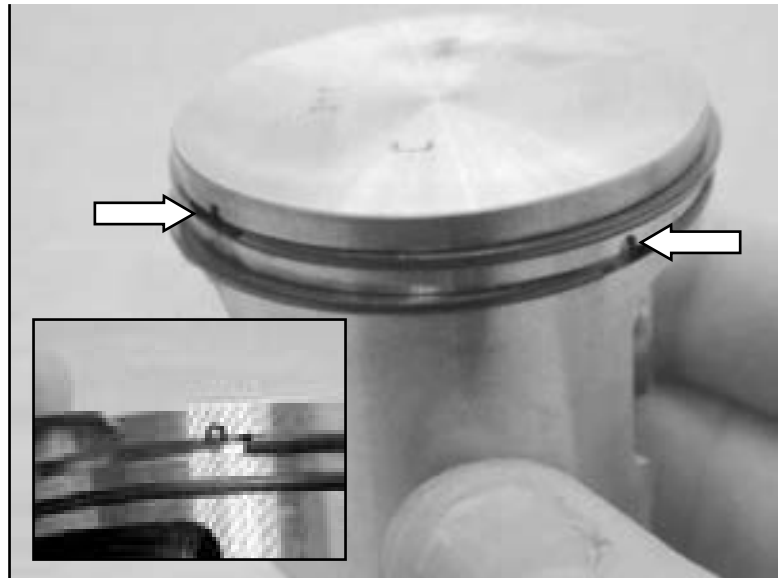

13.15 Install one (1) wrist pin retaining clip.



13.16 Make sure wrist pin retaining clip is in the proper orientation.

⚠ Improper installation may result in serious engine damage.

NOTE: Never attempt to reuse wrist pin retaining clips or substitute wrist pins from another model or brand. Install two new retaining clips with their open ends facing either to the six o'clock (toward the crankcase) or twelve o'clock (toward the cylinder head) position. Each retaining clip should produce an audible "click" as it seats in its groove in the piston.

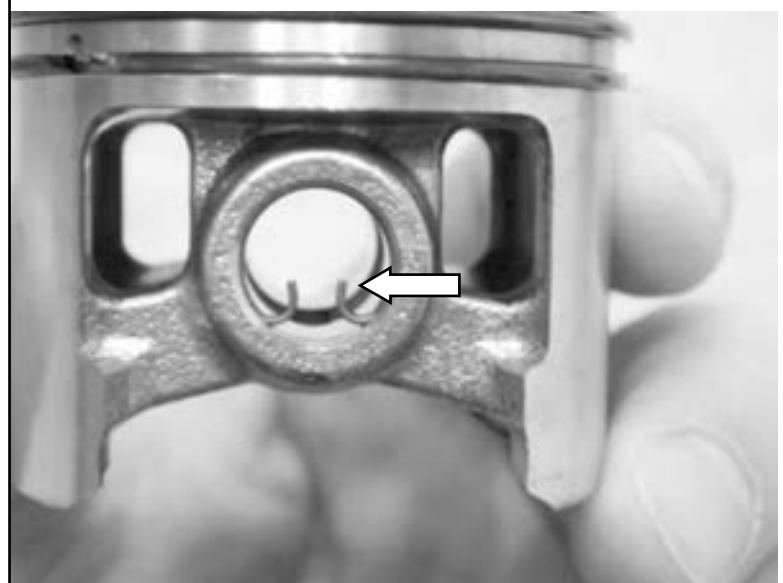

13.17 Lube and partially install wrist pin.



13.18 Align piston in correct orientation.

- A Make sure arrow points to exhaust port.

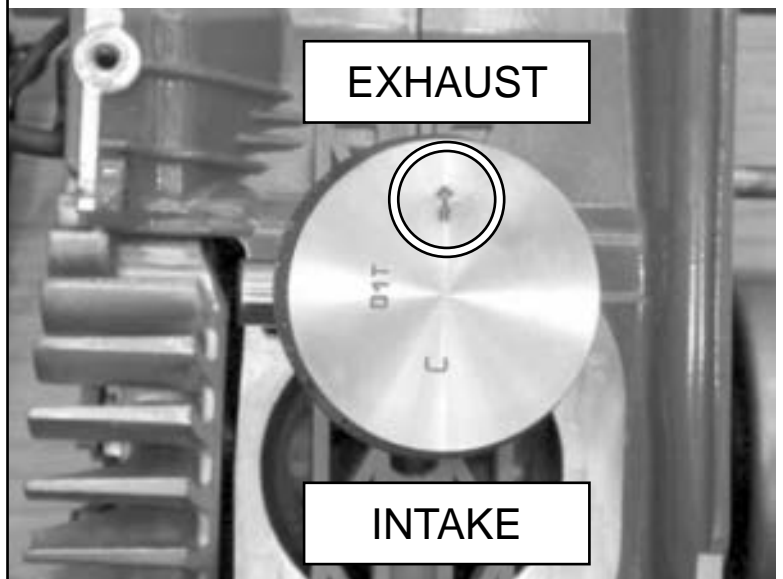

13.19 Install piston.

- A Oil piston with ICS® 2-stroke oil.
 - B Align wrist pin with wrist pin bearing.
 - C Complete wrist pin installation.
 - D Install second wrist pin retaining clip.
- ⚠ Make sure wrist pin retaining clip is in the proper orientation (see 13.16).



13.20 Install cylinder.

- A Lubricate cylinder bore with ICS® 2-stroke oil.
- B Compress rings with ring compression tool.
- C Slide cylinder onto piston, pushing ring compression tool down.



13.21 Install cylinder.

- A Remove ring compression tool.
- B Slide cylinder down piston and into crankcase.
- C Align cylinder bolt holes with crankcase.



13.22 Install (4) cylinder screws and washers.

- A Use Loctite® 242.
- B Torque bolts to 95 in-lbs. (10.7 Nm).



13.23 Install rear manifold.

- A Apply lightweight grease on the inside lip of the rear manifold.
- B Push rear manifold onto cylinder intake.
- C Align mold seams of intake boot with casting seams of the cylinder.

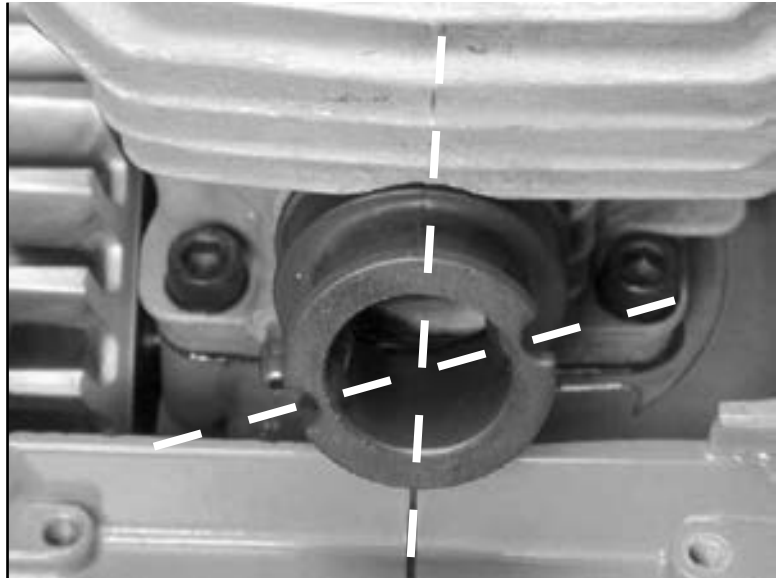

13.24 Install rear manifold clamp.

- A Torque to 11 in-lbs. (1 Nm).

NOTE: Insure that the intake boot is properly installed.

DO NOT OVER TIGHTEN INTAKE BOOT CLAMP.

If over tightened, intake boot can tear, resulting in an air leak which will cause engine damage.

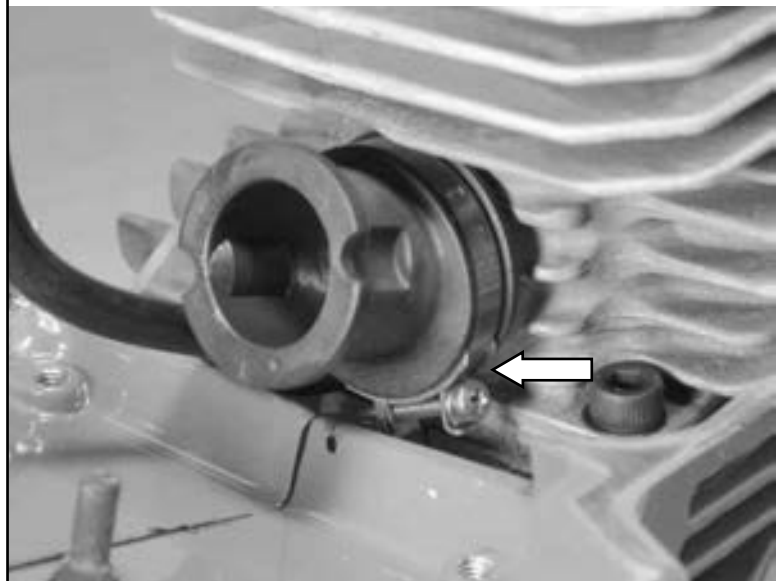

13.25 Install the pulse tube onto cylinder barb.

13.26 Install protective spring onto pulse tube.

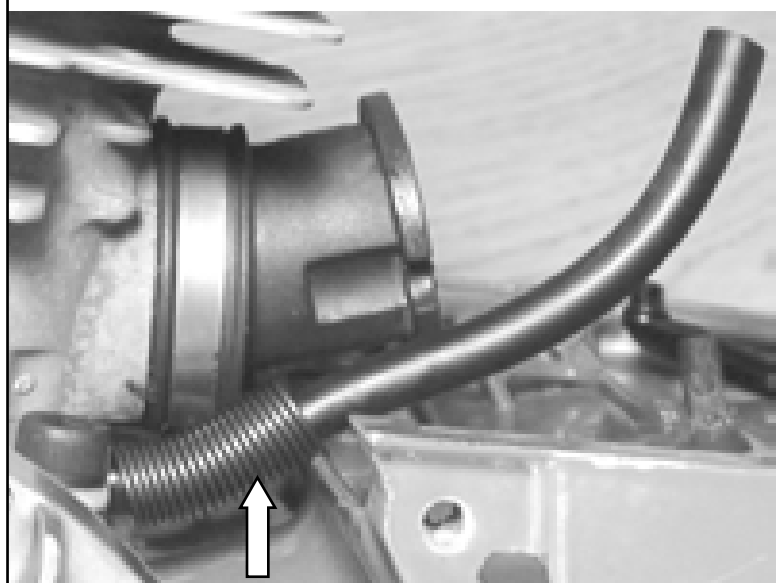

13.27 Install carburetor base.

- A Slip pulse tube into carburetor base.
- B Slip rear manifold into carburetor base.
- C Make sure rear manifold lip is flat.



13.28 Install carburetor base screws.

- A Use Loctite® 242 on screws (3).
- B Make sure to include stop switch wire on front screw.
- C Torque to 35 in-lbs. (4.0 Nm).

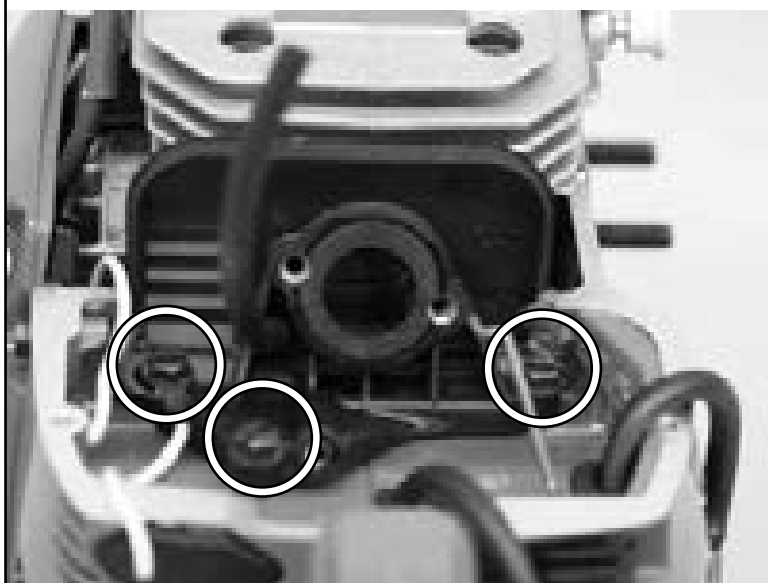

14 This section covers water hose and side cover.

14.1 Inspect water hose and side cover.

A Replace if damaged.

14.2 Assemble in reverse order.

14.3 Remove water hose connector from side cover.

A Remove clamp and hose from fitting.

B Unthread fitting from side cover.

14.4 Inspect side cover for damage.

A Replace if necessary.

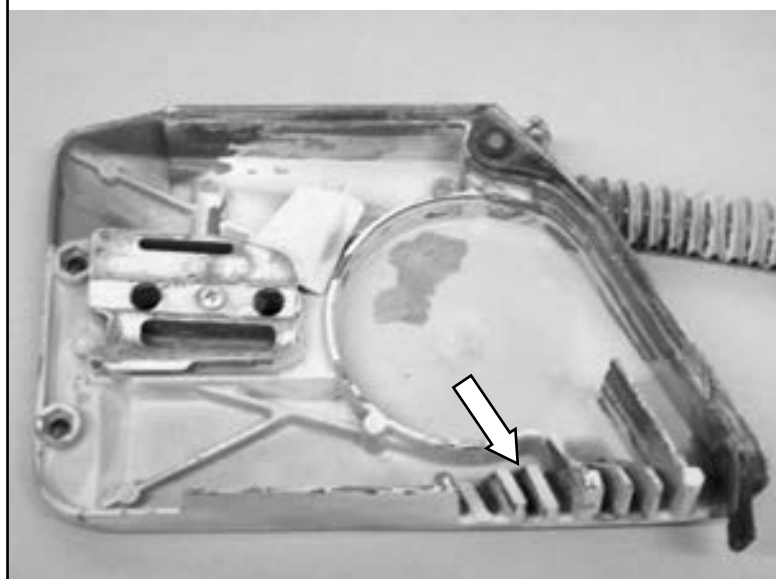

15 This section covers the removal, inspection, and installation of the ignition coil. Removal of the starter is required. Refer to section 8 if necessary.

15.1 Remove starter flywheel shroud by unhooking wires.

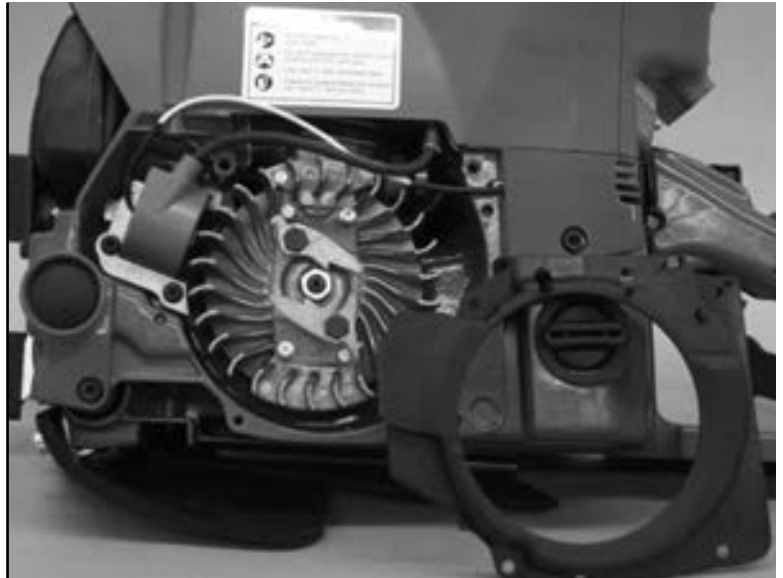

15.2 Remove ignition coil screws, wave washers and plain washers.

15.3 Remove ignition coil.



15.4 Inspect ignition coil.

A Look for:

- Cracks
- Missing insulation
- Wear marks in wire

B Clean flywheel magnets and coil if rusty.



15.5 Install Ignition coil.

- A Place ignition coil shim (0.012") on magnet counterweight side of flywheel.
- B Set ignition coil in place.
- C Install ignition coil screws, wave washers, and plain washers with Loctite® 242.
Holding shim, rotate flywheel magnet around to coil.
- E Torque ignition coil screws to 26 in-lbs. (2.93 Nm).
- F Remove shim, rotate flywheel to check clearance.

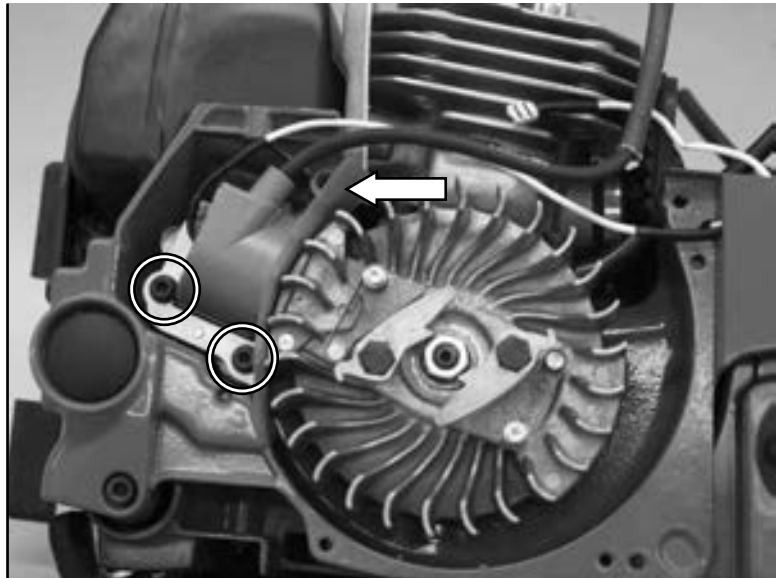

15.6 Install flywheel shroud.

- 15.7 Route yellow ignition stop switch wire through crankcase into carburetor chamber.



15.8 Complete ignition wire routing.

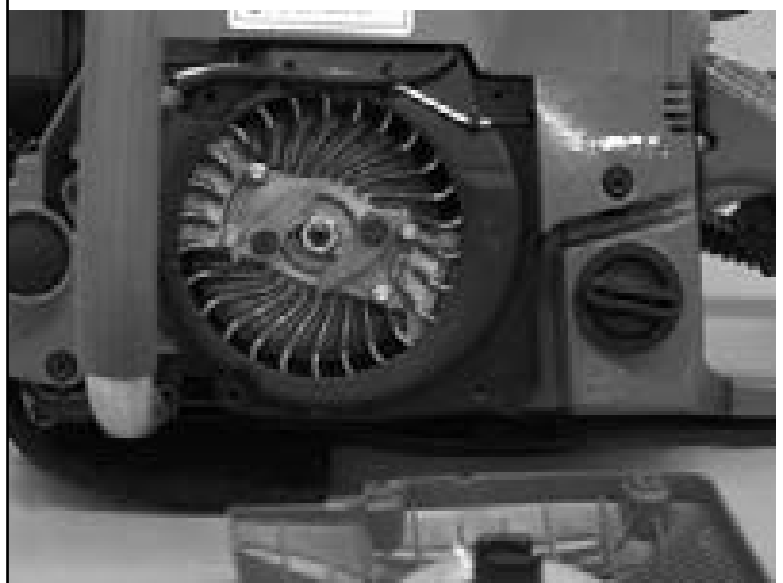

- 16** This section covers the removal, inspection, and installation of the flywheel. Removal of spark plug and the starter is required. Refer to sections 6 and 8 if necessary.

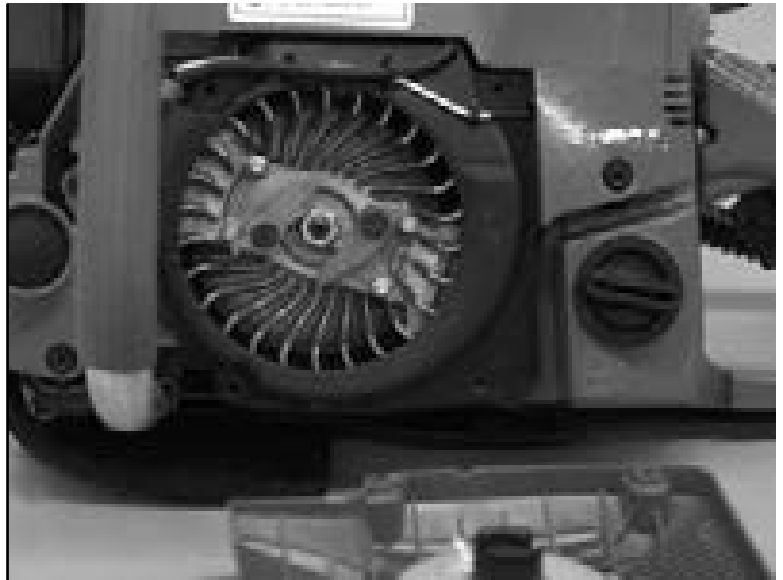

- 16.1 Insert piston stop.
16.2 Remove flywheel nut, wave washer, and plain washer.



- 16.3 Screw on flywheel removal tool finger tight. Unscrew tool 1 ½ turns leaving approximately 1/8 inch (4 mm) space between tool and flywheel.

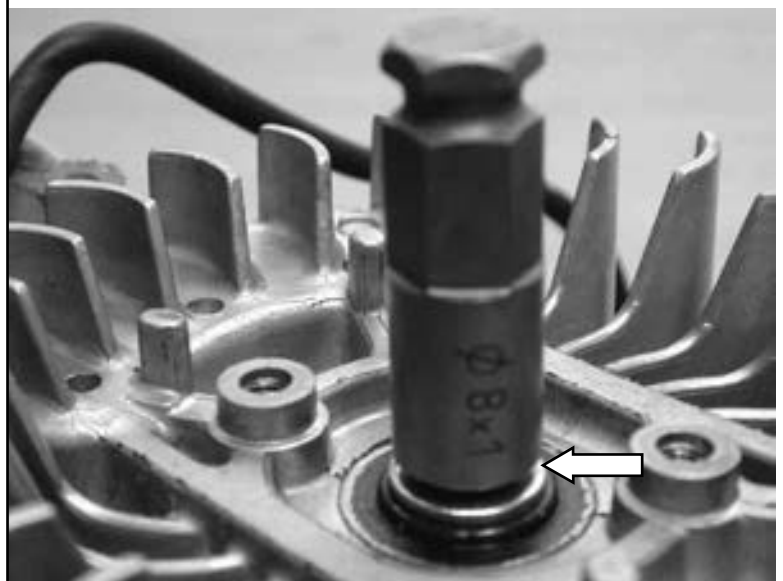

- 16.4 Using pliers, hold saw up by magnet counterweight.
- 16.5 Strike flywheel removal tool with a ball peen hammer. The flywheel should release from crankshaft.
- 16.6 Inspect and clean flywheel. Replace if any of the fins are broken.



- 16.7 Inspect cast woodruff key inside the flywheel.

NOTE: Key is cast into flywheel.

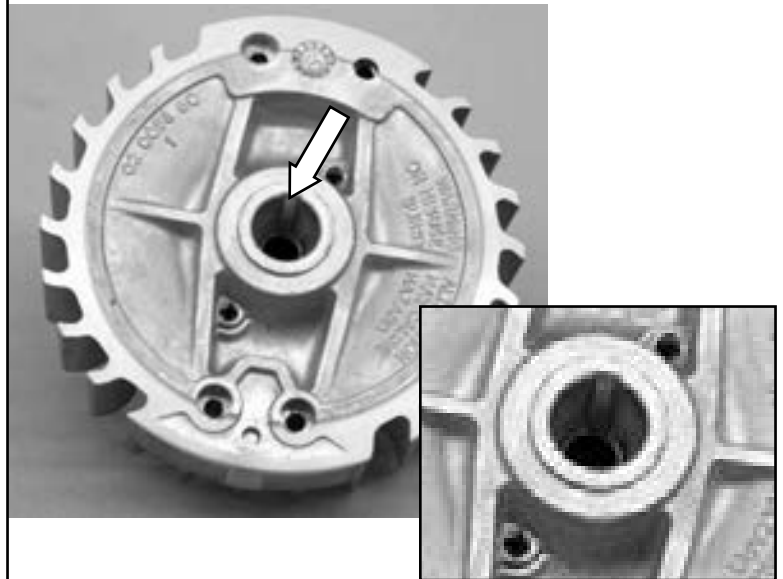

- 16.8 Install flywheel, plain washer, wave washer, and flywheel nut.
 - A Torque nut to 217 in-lbs. (24.5 Nm).



17 This section covers the removal, inspection, and installation of the front handle.

17.1 Remove front handle screws (2) on right side.

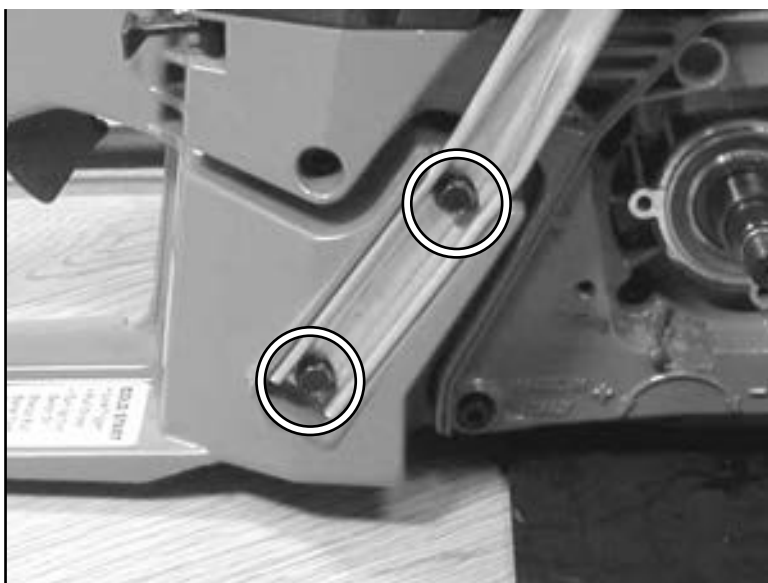

17.2 Remove front handle screws (2) on bottom.

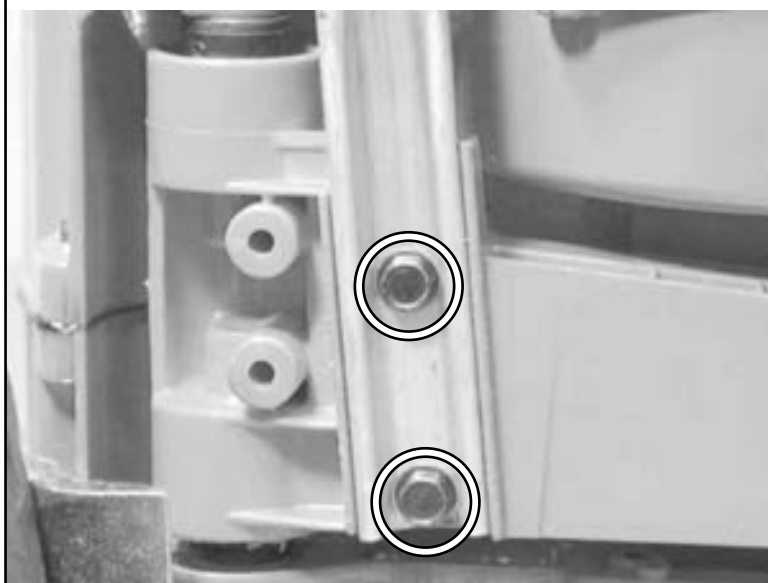

17.3 Install front handle.

- A Roll front handle into place.
- B Install front handle screws (4).
- C Use Loctite® 242.
- D Torque to 69 in-lbs. (7.8 Nm).

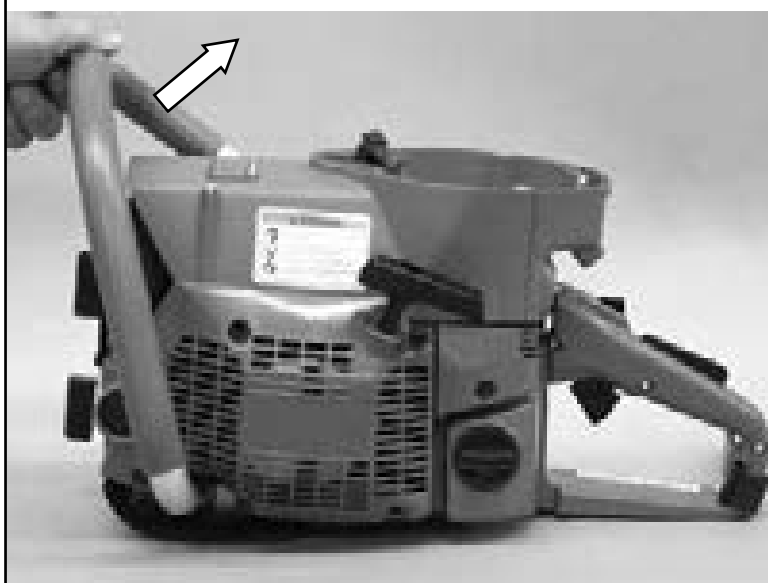

18 This section covers the disassembly, inspection, and assembly of the vibration isolaters, fuel tank, and rear handle.

18.1 Remove vibration isolator screws (2) and wave washers on clutch side of saw.

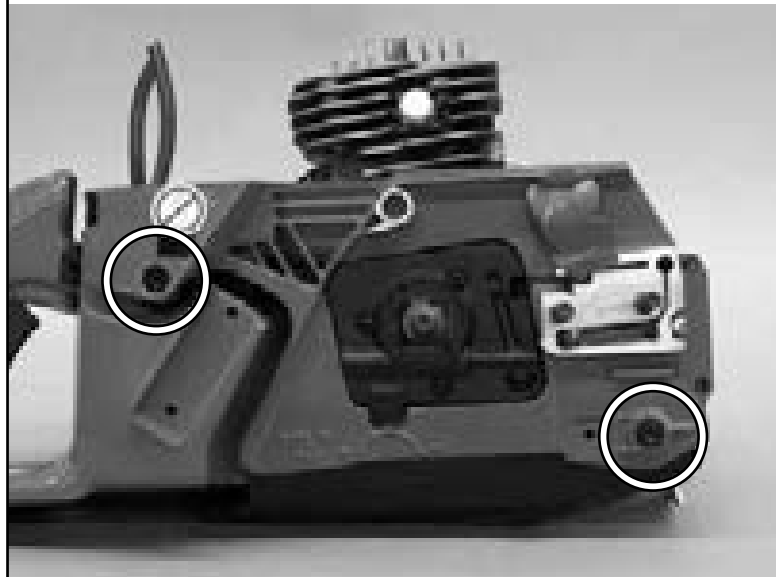

18.2 Remove vibration isolator screws (2) and wave washers on flywheel side of saw.

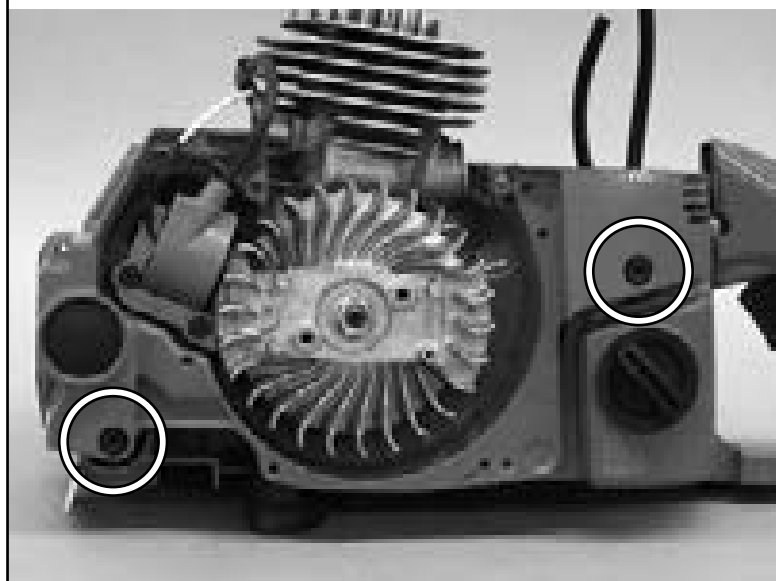

18.3 Separate crankcase and fuel tank.

NOTE: Saws have a rubber water deflector connected to the front vibration isolator on the clutch side (circled).

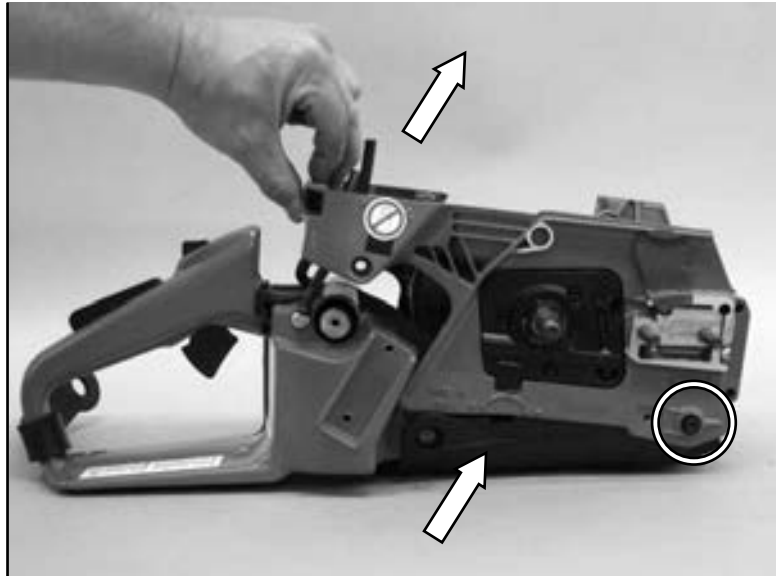

18.4 Remove vibration isolators (4) from fuel tank if necessary.

NOTE: Shock absorber tool (p/n #71546) must be used to remove vibrator isolators.



18.5 Assemble in reverse order.

NOTE: During assembly be careful to avoid kinking the fuel line.

Torque vibration isolators to 35 in-lbs. (4.0 Nm).

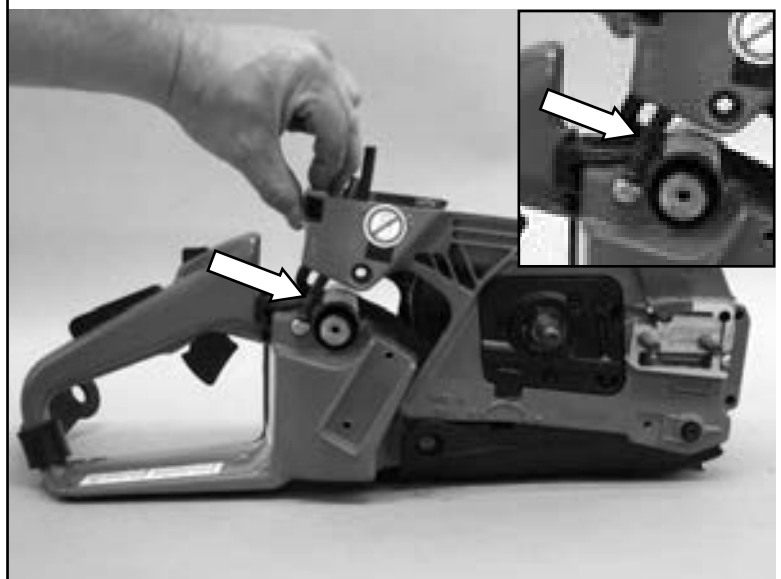

19 This section covers the disassembly, inspection, and assembly of the crankcase seals and crankshaft bearings.

19.1 Remove outer crankshaft seal housing screws (3) and wave washers.

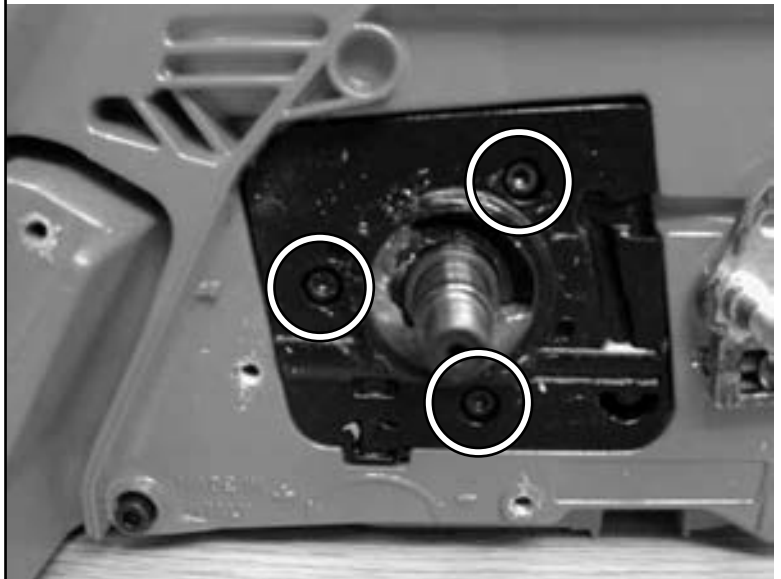

19.2 Remove crankcase bolts (5).

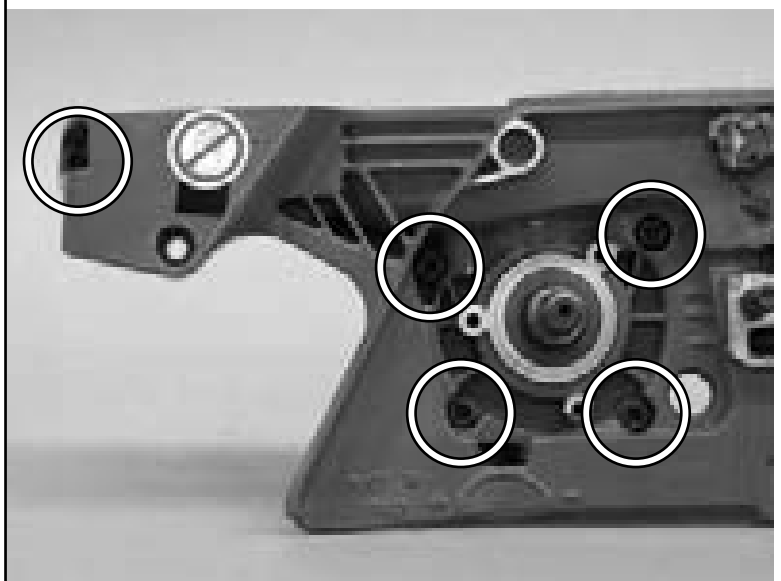

- 19.3 Heat the flywheel side crankcase with heat gun for 5 minutes, approximately 150° F (65.5° C).



- 19.4 Remove the flywheel side crankcase – tap crankshaft with plastic mallet.
- A Suspend above work surface.
 - B Tap with mallet.

NOTE: A nut should always be placed on a threaded shaft when pounding or pressing on it.



- 19.5 Remove the flywheel side crankcase seal with 1/2" (13 mm) socket.



- 19.6 Disassembly of crankcase.
Heat the clutch side crankcase with heat gun to 150° F (65.5° C).

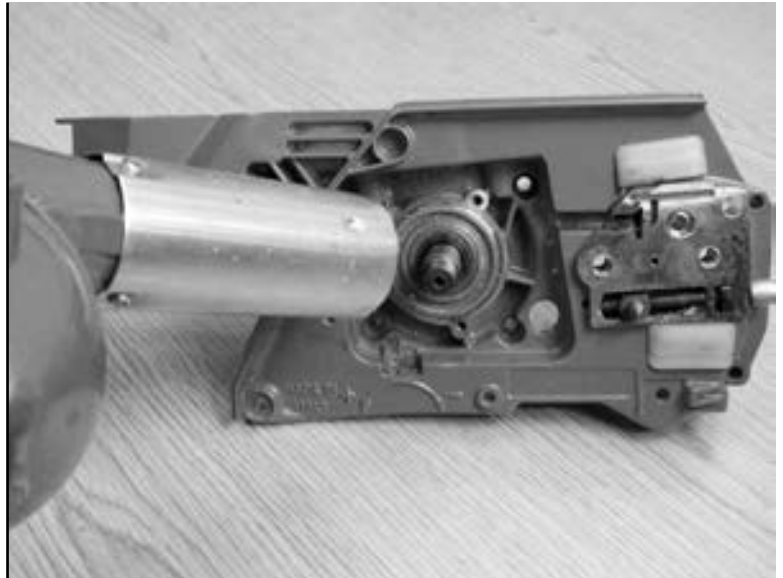

- 19.7 Remove crankshaft from the clutch-side crankcase tap crankshaft with a plastic mallet.
- A Suspend above work surface.
 - B Tap with plastic mallet.



- 19.8 Remove the bearing from the flywheel side of crankshaft.



19.9 Remove the bearing, seal, and bushing from the clutch side of crankshaft.



19.10 Assembly of crankcase.

A Clean mating crankcase faces.

19.11 Heat crankcase halves to 150° F (65.5° C).



19.12 Install bearing into crankcase halves.

19.13 Tap with bearing driver and mallet.



19.14 Repeat with other half.



19.15 Install crankshaft into clutch side of case.



19.16 Place clutch side crankcase seal on crankshaft.

- A Tap lightly with bearing driver and mallet.



- 19.17 Coat crankcase gasket with ICS® 2-stroke engine oil.



- 19.18 Align crankcase gasket on flywheel side crankcase pins.

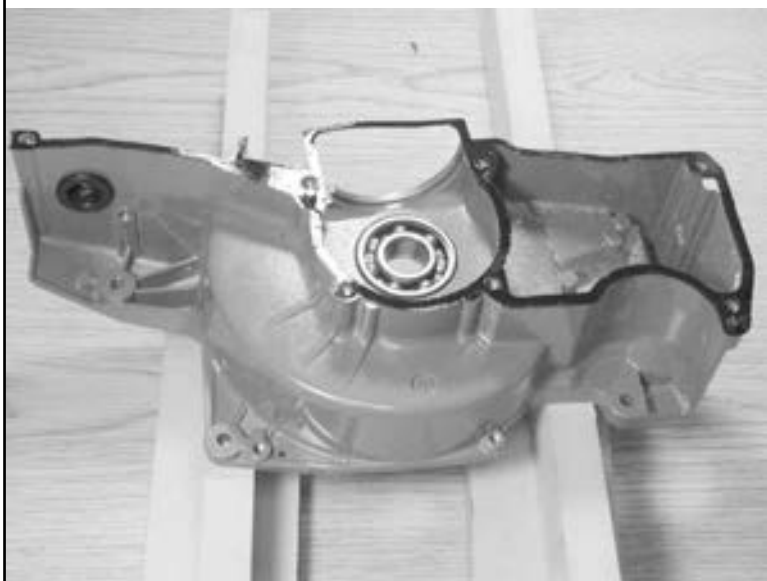

- 19.19 Place crankcase halves together and align crankcase pins.



19.20 Assemble crankcase halves –
tap with bearing driver and mallet.



19.21 Install crankcase bolts (5).

A Use Loctite® 242.

B Torque to 70 in-lbs. (7.9 Nm).

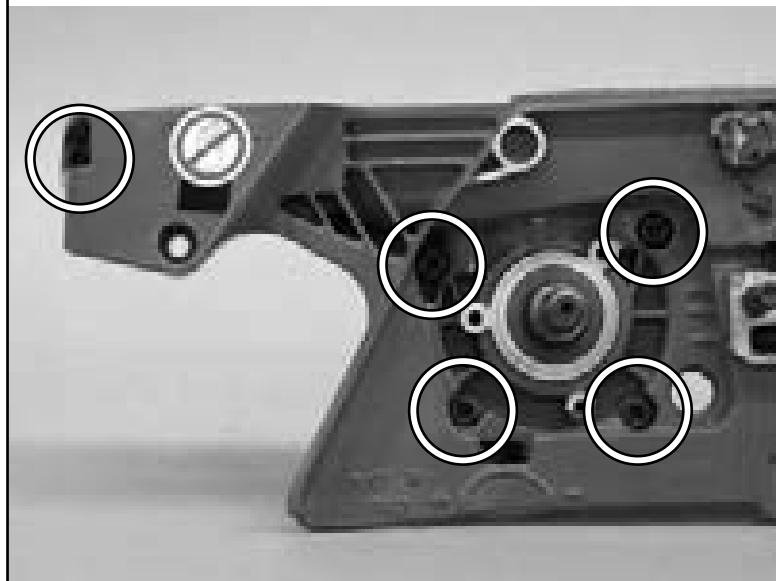

19.22 Install flywheel side crankcase seal –
tap with bearing driver and mallet.

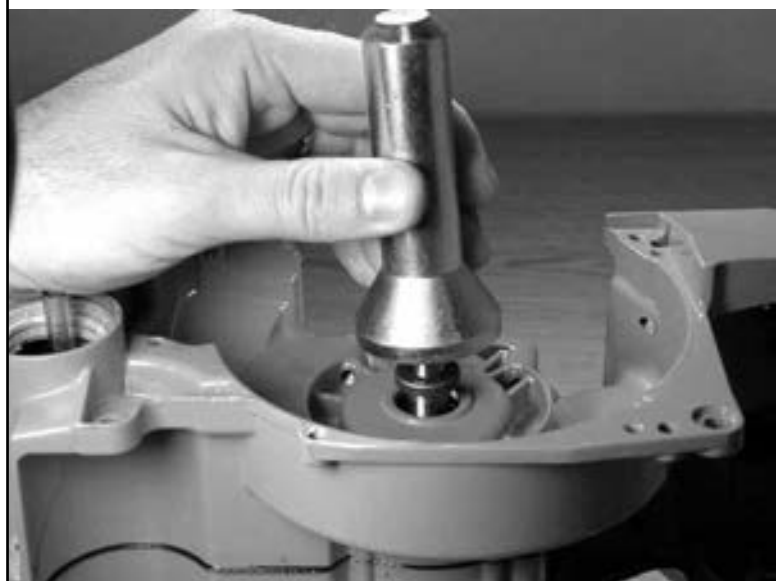

19.23 Assemble in reverse order

- A Install outer crankshaft seal housing with 3 bolts and use Loctite® 242.

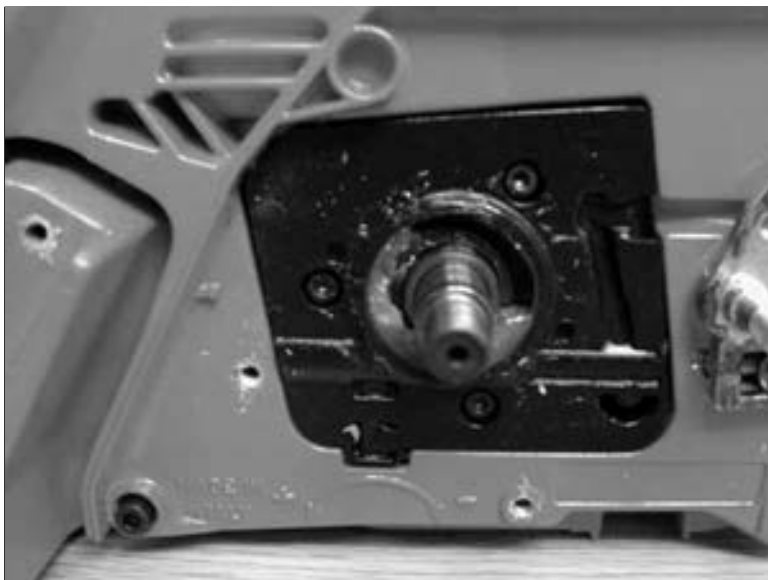

19.24 Trim crankcase gasket flush.



20 This section covers the removal and installation of the bar studs and bar pad.

20.1 On 660GC saws:

NOTE: This requires the removal of the piston and cylinder, and to split the crankcase. (Refer to section 13 & 19 for detailed instructions)

- A Remove side cover.
- B Remove bar pad cover.

- C Split the crankcase.

- D Press out bar studs.
- E Assemble in reverse order.

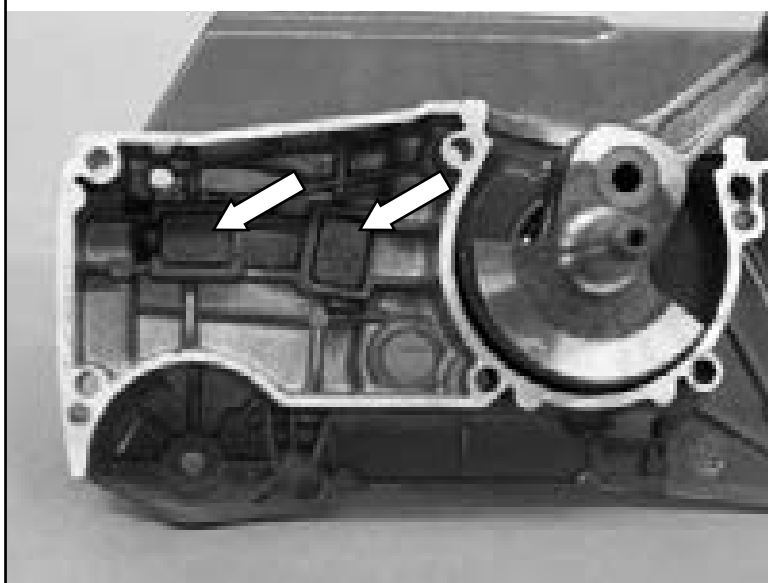
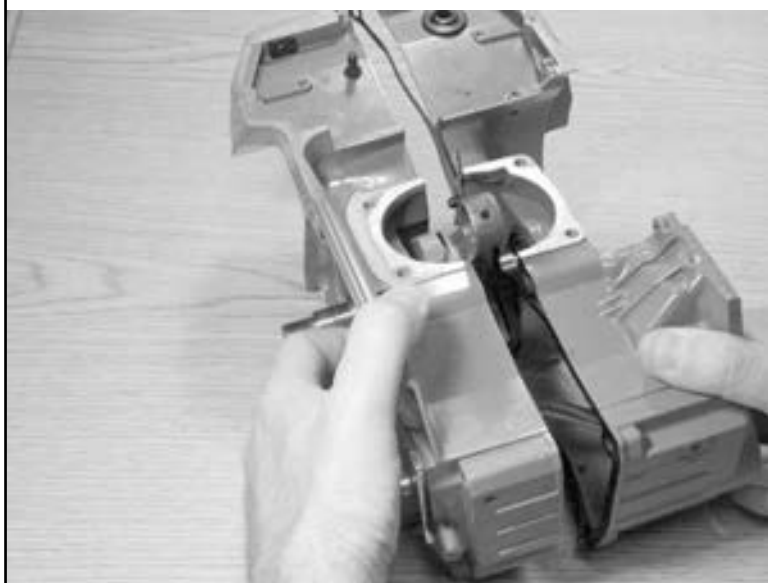

21 This section covers the removal and installation of the chain tensioner.

21.1 Remove bar plate to expose the chain tensioner.



21.2 Unscrew tensioner to remove.

A Remove tensioner pin.

B Remove tensioner screw keeper.

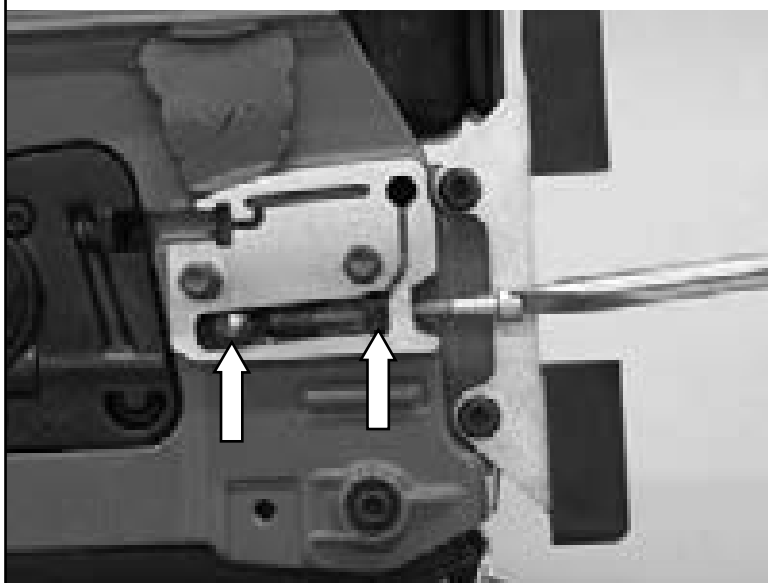

21.3 Assemble in reverse order.

NOTE: The tensioner is intended to perform as a fuse in high load or sudden impact situations.
(p/n 505393)



- 22 This section covers carburetor tuning. Included in this section are basic settings, idle speed adjustment, and complete adjustment.

The carburetor on a new saw is set at the factory for optimal performance and compliance to EPA Phase II emissions standards. However, minor adjustments may be required in certain conditions, such as high elevation. A replacement carburetor is not set correctly from the factory. Use the tuning instructions in this manual to adjust carburetor to factory-recommended settings. (DO NOT adjust the carburetor for maximum rpm. Adjusting the carburetor for maximum rpm will cause engine damage). **Always set the carburetor jets to factory settings when replacement or complete rebuild becomes necessary.**

NOTES:

- These saws are equipped with an electronic speed limiter, as part of the ignition system. This will prevent the saw from going above 12,500 rpm. Attempting to set the carburetor mixture to increase the speed or power beyond this limit may seriously damage the engine.
- Always check the air filter, pre filter, fuel filter, and spark plug before making carburetor tunings and clean or replace if necessary

22.1 Basic Setting -

H = 1 turn from closed

L = 1 turn from closed

Complete carburetor readjustment.

RPM Settings for saws.

NOTE: Saw tuned without bar and chain installed.

Idle Speed = 3,000 ± 500 rpm

Full Throttle = 12,500 ± 500 rpm

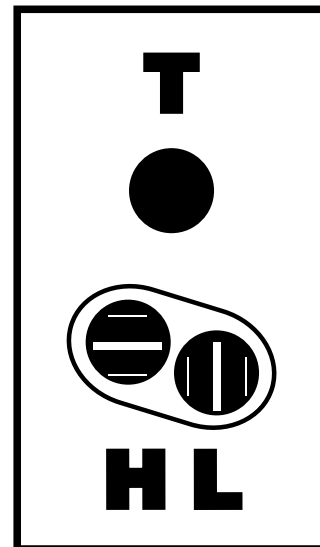

22.2 Remove limiter cap.

A. Limiter caps can only be removed after the cylinder cover and screw boot have been removed. Observe orientation of the release slots on the adjustment screw limiter cap. See section 10 for cylinder cover removal.

B. Insert the limiter cap puller into the center of the limiter cap.

C. Firmly hold the tool shaft while screwing in the puller screw until the screw head is against the puller shaft.

D. Unscrew the puller screw, 1/4 turn and pull straight out. Repeat for second limiter cap.



22.3 Using a 5/64" straight blade screwdriver, gently turn the adjustment screws clockwise until completely closed.

22.4 Set the adjustment screws at the Basic Setting:

H = 1 turns from closed

L = 1 turns from closed

- ⚠** The side cover must be held tightly in place with the side cover nuts, using a bar and no chain. Failure to do so may result in personal injury.



22.5 Start the saw and warm up the engine.

22.6 With a tachometer check the saw rpm, with bar and no chain:

- A Idle = 3,000 ± 500 rpm
- B If the idle rpm does not fall into this range, adjust the T screw, clockwise to raise RPM, counterclockwise to lower RPM.



22.7 With a tachometer check the saw full throttle rpm, with a bar and no chain:

A Target = $12,500 \pm 500$ rpm

22.8 If the full throttle rpm falls below this range, turn the H screw in (clockwise) $1/16^{\text{th}}$ of a turn at a time.

A Pulse the throttle to help stabilize the system.

⚠ Do not hold the saw at max rpm for more than 5 seconds or cylinder damage could occur.



23 This section covers idle speed adjustment.

23.1 If engine stops while idling:

- A Make sure the chain is properly tensioned.
- B Turn T screw clockwise until chain begins to move.
- C Back T screw out $\frac{1}{2}$ turn.

23.2 If chain turns at idle:

- A Back T screw out until chain stops moving.

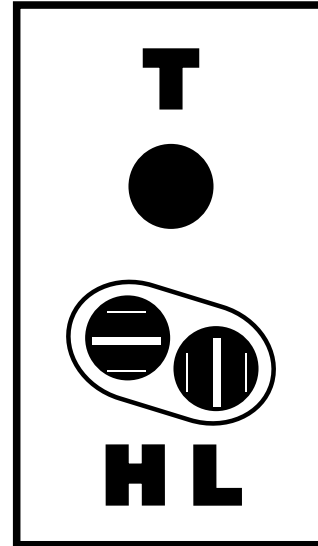

24 This section provides several flowcharts to aid diagnosing common problems.

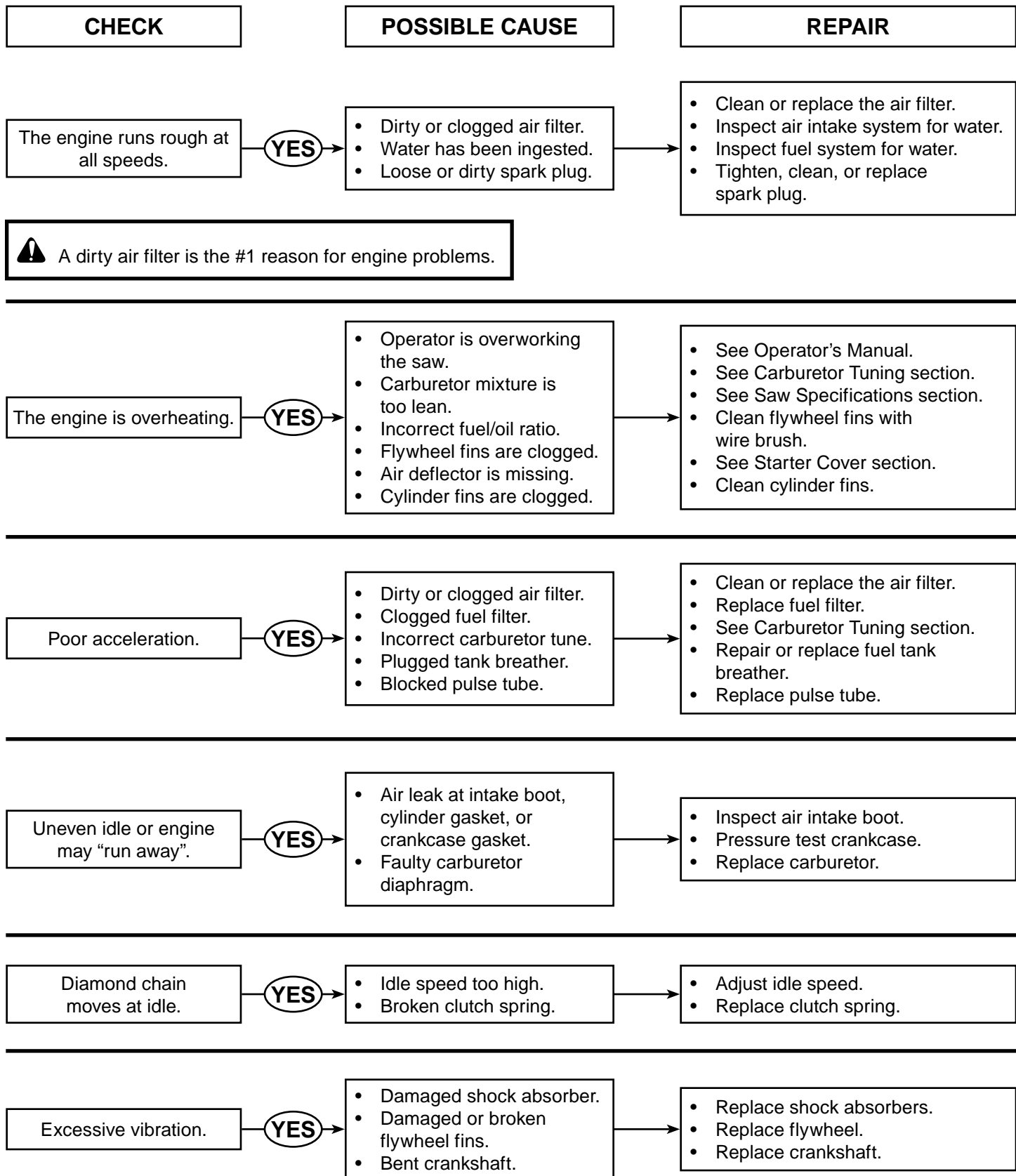

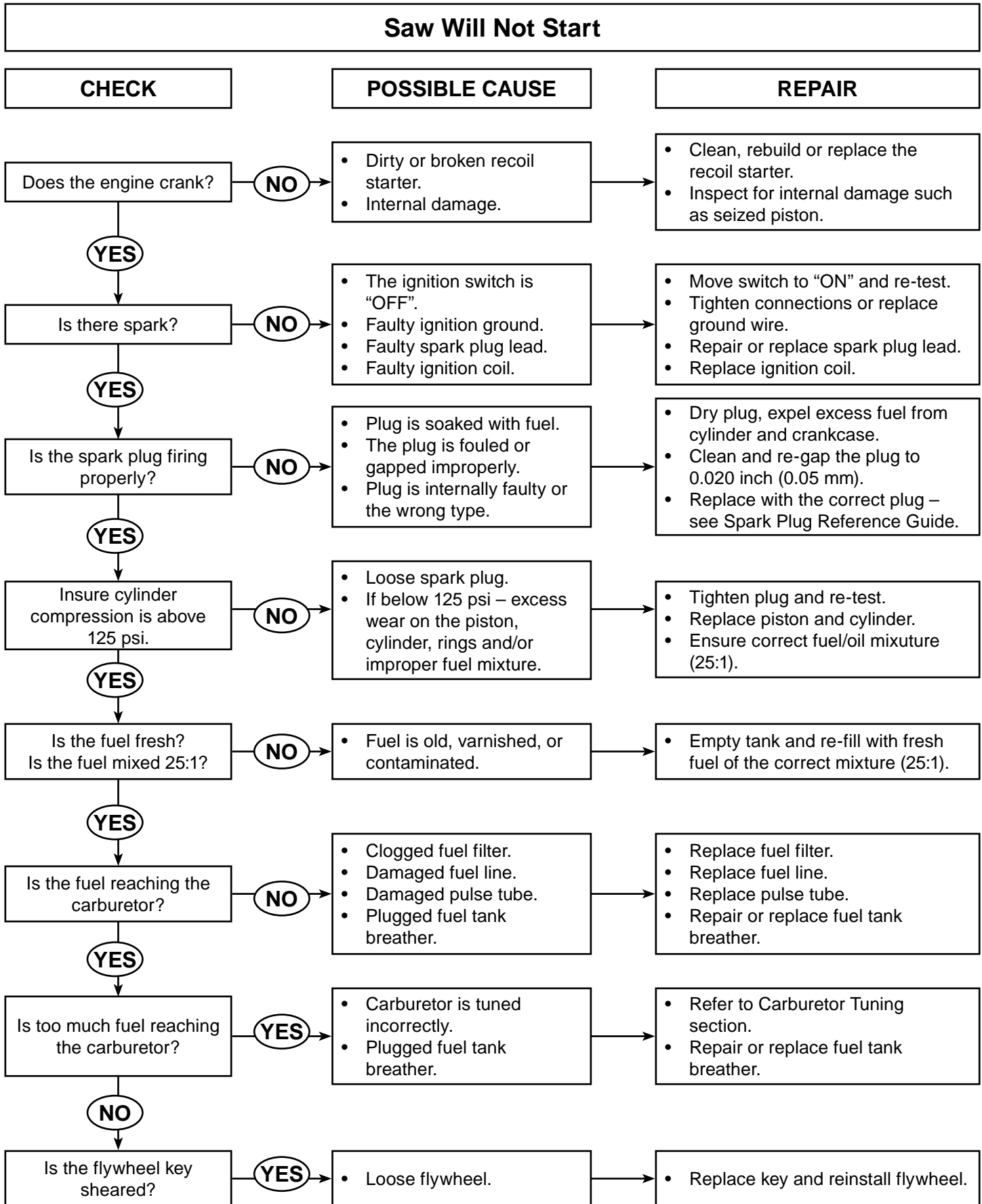

25 This section covers testing the fuel system for leaks. Engine starvation can result from a leak or malfunction of any of the main components of the fuel system. The five main components are the fuel tank, fuel tank breather, fuel filter, delivery tubes, and carburetor.

- 25.1** Remove and inspect the fuel filter.
- A Replace the fuel filter if there is any foreign material in the felt or the internal screen.

- 25.2** Test the main fuel pick-up tube for leaks.
- A Connect tube to the pressure gauge and to the fuel line.
 - B Pressurize the tube to 7psi (0.5 bar).
 - C If the pressure does not maintain, separate the fuel line from the carburetor.



- D Plug one end of the main fuel pick-up tube.
- E Re-pressurize the tube to 7psi (0.5 bar).
- F Replace the tube if pressure is not maintained.
- G If the main fuel pick-up tube does maintain pressure, then the leak has been isolated to the carburetor. Refer to the Walbro Diaphragm Carburetor Service Manual.

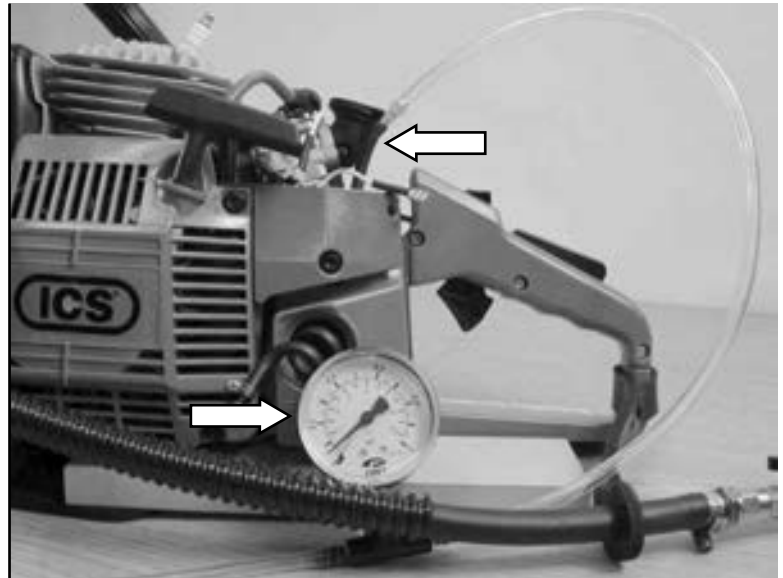

- 25.3 The fuel tank breather stabilizes the pressure in the fuel tank preventing both excessive pressure, which could flood the engine, and negative pressure, which could starve the engine of fuel.
- 25.4 Fuel tank breather is located inside the air filter compartment.



- 25.5 Testing the fuel tank breather.
 - A Attach the pressure gauge and bulb to the fuel tank breather. Pressurize the tube to 7psi (0.5 bar).
 - B The pressure should reduce to nearly 0 psi (0 bar) over about 3 seconds.

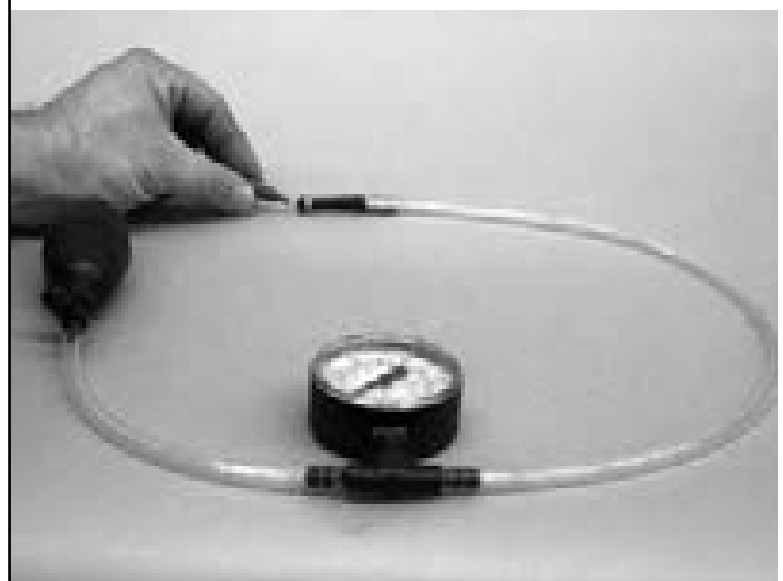

- 25.6 If the pressure does not reduce to 0 psi, disassemble or replace the breather.
- A Disassemble by snapping off cap.
 - B Clean parts with solvent or fuel.

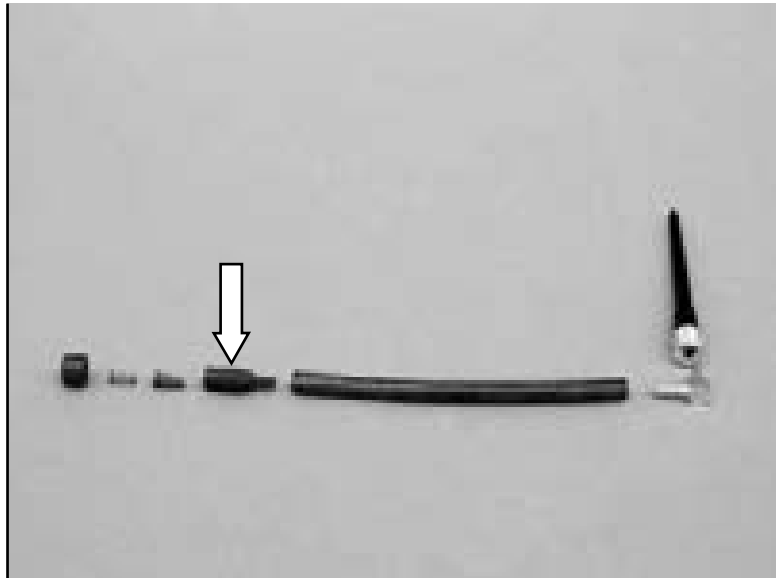

- 25.7 Assemble in reverse order.
- A Make sure duck bill opens easily.
 - B Make sure that the spring taper is oriented in the correct direction.
 - C Assemble by snapping cap in place.

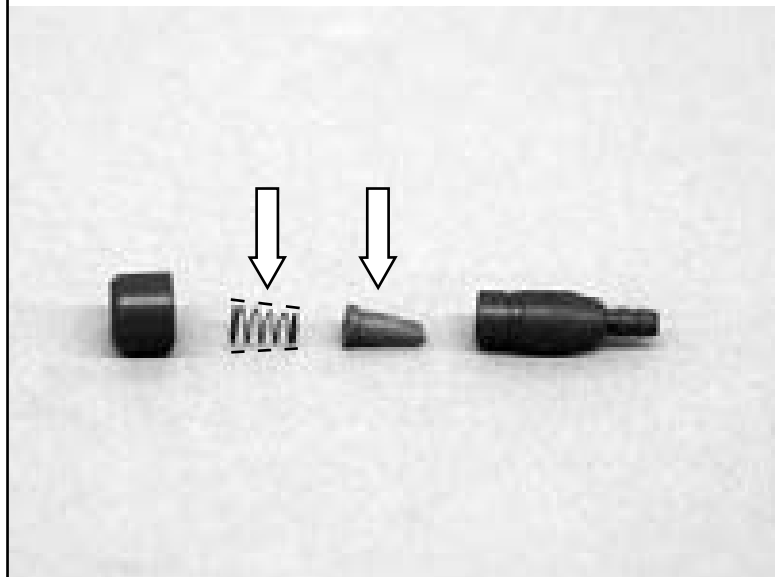

26 This section covers testing the crankcase for leaks. A leak in the crankcase can cause the engine not to run.

26.1 Install the intake seal flange.

A Plug cylinder pulse tube.

26.2 Install the exhaust seal flange.

26.3 Block one of the flange tubes with a rubber plug.

26.4 Install the pressure gauge and bulb.

26.5 Pressurize the crankcase to 7psi (0.5 bar).

26.6 If the pressure does not remain the same, use soapy water to find the leak.

NOTE: It is recommended that this test be performed after an engine rebuild.

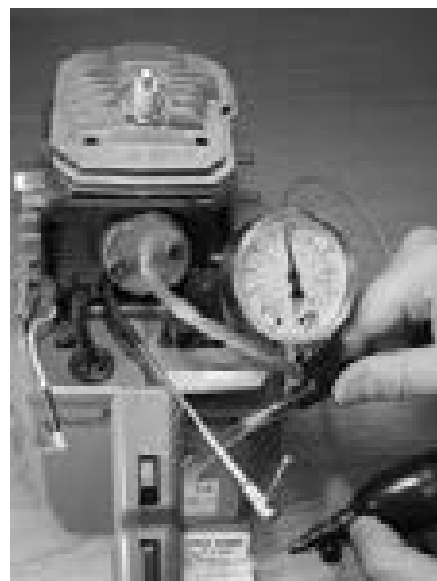
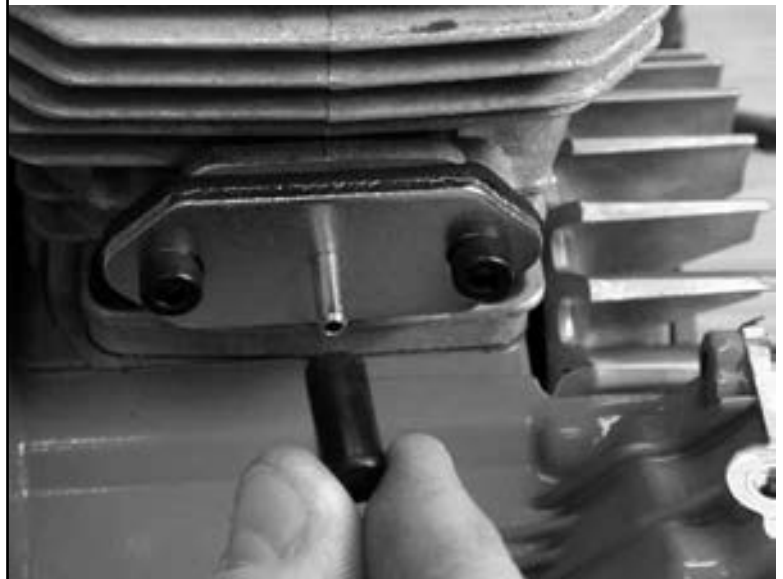
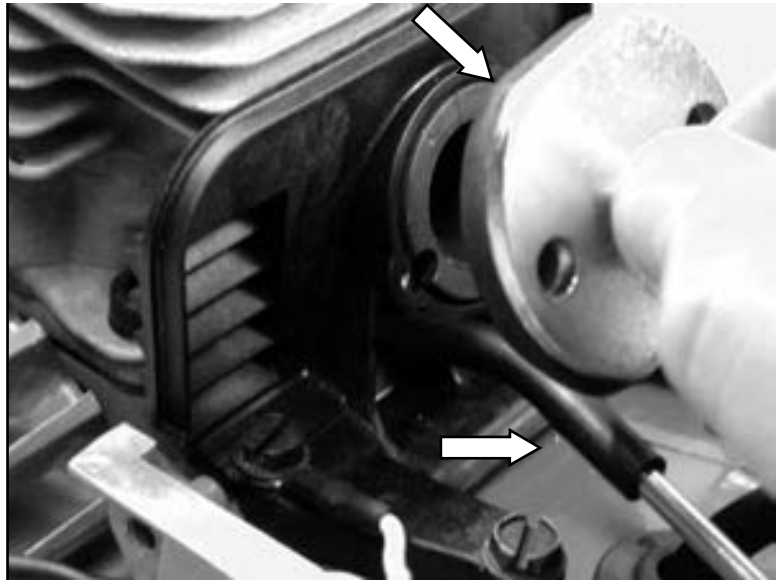

- 1 The Spark Plug Reference Guide is to be used as a guide only. When trying a plug from a different manufacturer, perform a plug check to be sure that the plug will work.

SPARK PLUG REFERENCE GUIDE			
ICS RESISTOR	CHAMPION RESISTOR	NGK RESISTOR	BOSCH RESISTOR
73199	RCJ7Y	BPMR7A	WSR7F

ICS, Blount, Inc.
4909 SE International Way
Portland, OR 97222, USA
Tel 800.321.1240 Fax 503.653.4393

ICS, Blount Europe S.A.
Rue Emile Francqui, 5
1435 Mont-Saint-Guibert, Belgium
Tel +32 10 301 251 Fax +32 10 301 259
icsdiamondtools.com