

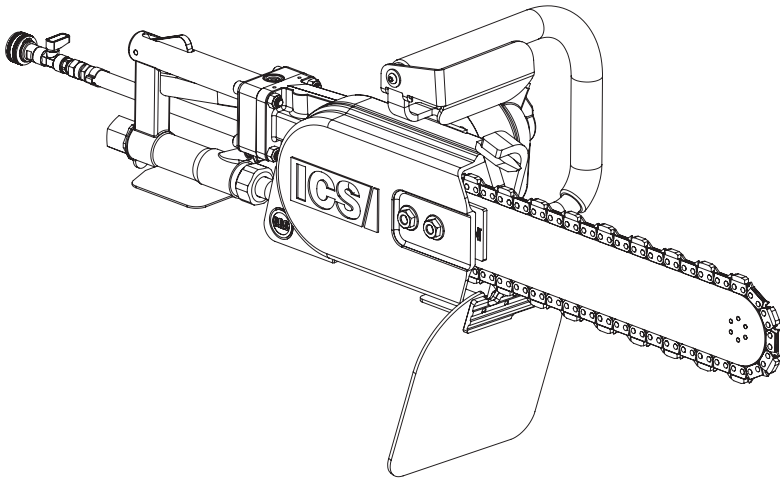

**Diamond Tools and Equipment  
for Construction and Infrastructure**



**Model # 701-A  
OPERATOR'S MANUAL**

## **INTRODUCTION**

This manual outlines the maintenance and operation of ICS® manufactured products.

This is a professional tool and is solely intended for use by trained and experienced operators.

The 701-A Series power cutter is designed to cut concrete, stone, and masonry when used with the appropriate genuine ICS Diamond Chain. Other materials including ductile iron, cast iron or PVC pipe require the use of ICS PowerGrit® Utility Chain.

To get the maximum benefit from your power cutter, and ensure maximum safety, be sure to read this manual thoroughly, and periodically review safety instructions.

**TABLE OF CONTENTS**

<b>SYMBOLS &amp; LABELS</b>	<b>4 - 5</b>
<b>NAMES &amp; TERMS</b>	<b>6 - 7</b>
<b>SAFETY</b>	<b>8 - 10</b>
<b>TECHNICAL SPECIFICATIONS</b>	<b>11</b>
<b>SET-UP</b>	<b>12 - 17</b>
<b>OPERATION</b>	<b>18 - 23</b>
<b>TROUBLESHOOTING</b>	<b>24</b>
<b>MAINTENANCE</b>	<b>25-26</b>
<b>REFERENCE</b>	<b>27</b>
<b>DECLARATION OF CONFORMITY</b>	<b>28</b>

**SAFETY RULES**

To get the maximum benefit from your power cutter, and ensure maximum safety, be sure to read this manual thoroughly and follow the safety instructions provided.

**EXPLANATION OF WARNING LEVELS**



Indicates a hazard with a high level of risk which, if not avoided, will result in death or serious injury.



Indicates a hazard with a medium level of risk which, if not avoided, could result in death or serious injury.



Indicates a hazard with a low level of risk which, if not avoided, could result in minor or moderate injury.

**IMPORTANT**

Indicates a potential situation exists which, if not avoided, may result in damage to your power cutter or property.



XX = Year of Manufacture (ie. 15)

YY = Month of Manufacture (ie. 07)



ZZZZ = Power cutter number within production batch in sequential order beginning with 0001

**SYMBOLS AND LABELS**

THE FOLLOWING SYMBOLS ARE FOUND THROUGHOUT THIS MANUAL AND/OR ON THE POWER CUTTER AND ARE DESIGNED TO MAKE YOU AWARE OF POTENTIAL HAZARDS OR UNSAFE PRACTICES.

				
<p><b>SAFETY ALERT</b> Indicates that the text that follows explains a danger, warning or caution.</p>	<p><b>READ INSTRUCTIONS</b> The original instruction manual contains important safety and operating information. Read and follow the instructions carefully.</p>	<p><b>WEAR PROTECTION</b> Wear eye, hearing and respiratory protection and a protective helmet when operating the power cutter.</p>	<p><b>BEWARE OF KICKBACK</b> Kickback can cause severe injuries.</p>	<p><b>TWO-HANDED HOLD</b> Operate the power cutter with two hands, securely gripping both handles</p>
				
<p><b>WEAR LONG PANTS</b> Wear long pants when operating the power cutter.</p>	<p><b>WEAR FOOT PROTECTION</b> Wear appropriate closed-toe boots when operating the power cutter.</p>	<p><b>WEAR HAND PROTECTION</b> Wear hand protection when operating the power cutter.</p>	<p><b>ONE-HANDED HOLD</b> Do not operate the power cutter with only one hand.</p>	<p><b>DO NOT USE A LADDER</b> Never stand on a ladder when using the power cutter.</p>
				
<p><b>KERF WIDTH</b> Do not insert tool into slot narrower than chain.</p>	<p><b>PNEUMATIC POWER</b></p>	<p><b>SOUND POWER</b> Sound power level is 113 dB(A).</p>	<p><b>FIRE DANGER</b> Risk of fire if warnings not followed.</p>	<p><b>SLIPPERY SURFACE</b> Unsure footing can lead to accidents.</p>

## 701-A NAMES AND TERMS

### Baffle Drain

A device for controlling slurry and cutting debris in the side cover to reduce chain stretch and protect the operator from other projectiles.

### Bar retaining plate

The plate between the guidebar and side cover that clamps the guidebar to prevent movement during operation.

### Bar pad

The mounting pad on the powerhead that helps assure proper alignment of the guidebar.

### Bar slot

The slot feature on the guidebar that fits over the alignment block and bar stud.

### Bystander safety zone

A 6 m (20 ft) circle around the operator that must remain free from bystanders, children and pets.

### CFM

CFM stands for cubic feet per minute. This is the air flow or air volume that a compressor can supply – or its output.

### Chain catcher

A device for retaining the chain if it breaks or derails.

### Chain pitch

The distance between any three consecutive rivets on the chain divided by two.

### Chain tensioning screw

An adjustment screw used to set proper tension on the chain and compensate for chain stretch from normal use.

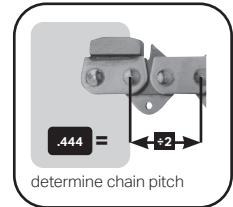

### Front handle

The support handle located at or toward the front of the power cutter intended to be gripped by the left hand.

### Guidebar

A railed structure that supports and guides the chain. Sometimes simply called the “bar”.

### GPM

GPM means Gallons Per Minute. Also known as “flow rate”, GPM is a measure of how many gallons of **water** flow out of your water hose each minute.

### Kickback

The rapid backward and/or upward motion of the guidebar, occurring when the chain near the top area of the nose of the guidebar contacts a foreign object or snags in the workpiece.

### LPM

LPM means Liters Per Minute. Also known as “flow rate”, LPM is a measure of how many liters of **water** flow out of your water hose each minute.

**Mud flap**

A barrier to protect the operator from cutting debris and other projectiles.

**Powerhead**

A power cutter without the chain or guidebar.

**PSI**

PSI means pounds per square inch. It measures how much force is in a certain area – one pound-force applied to one square inch.

**Pushback**

The rapid backward motion of the guidebar, occurring when the chain on the top straight portion of the guidebar contacts a foreign object or snags in the workpiece.

**Rear handle**

The support handle located at or toward the rear of the power cutter intended to be gripped by the right hand.

**Rear hand guard:**

A structural barrier at the bottom right side of the rear handle to protect the operator in case the chain breaks or derails.

**Side cover:**

The component on the powerhead that covers the drive sprocket and directs debris away from the operator during use.

**Side cover nut:**

The component on the side cover that secures the side cover and guidebar.

**Throttle trigger lock-out**

A device that prevents the unintentional operation of the throttle trigger until manually released.

**Throttle trigger**

A mechanism that controls engine RPM.

**WallWalker®**

A device used as a fulcrum to provide mechanical advantage during cutting.

**Water shut-off valve**

A mechanism that controls water delivery and flow to the guidebar and chain.

**THE FOLLOWING WARNING SYMBOL APPLIES TO ALL THE ITEMS LISTED ON THIS PAGE**

Indicates a hazard with a medium level of risk which, if not avoided, could result in death or serious injury.

**Note: Chain breakage can result in high-speed ejection of parts, which can result in death or serious personal injury to operators or bystanders. The items listed immediately below are critical to minimizing the risk of chain breakage and injury.**

- **DO NOT operate the power cutter with damaged, modified or missing components shown below.**
  - Side cover
  - Mud flap
  - Rear hand guard
  - Mud flap bracket (chain catcher)
  - Trigger interlock
  
- **DO NOT exceed 90 psi (6 bar) operating pressure.**
  
- **DO NOT insert the diamond chain power cutter into a slot narrower than the chain segments.**

Rapid pushback might occur.

*NOTE: Most ICS diamond chain segments are .225 inches (5.72 mm) wide.*
  
- **NEVER run a diamond chain power cutter upside-down.**

Concrete debris can fly back into the operator's face.
  
- **NEVER cut ductile iron pipe with concrete chain.**

Segment loss or chain breakage may occur.
  
- **NEVER operate the ICS power cutter with a saw chain or saw bar designed to cut wood.**

Using wood cutting saw chain on the ICS power cutter could result in severe injuries to operator and bystanders! Use ONLY the cutting attachments specified in this manual on this power cutter.



**THE FOLLOWING WARNING SYMBOL APPLIES TO ALL THE ITEMS LISTED ON THIS PAGE**

Indicates a hazard with a medium level of risk which, if not avoided, could result in death or serious injury.

**This power cutter can generate hazardous dust and vapors.**

Determine the nature of the material you are going to cut before proceeding with the job. Be especially aware of cutting materials containing silica and asbestos as inhaling dust can result in respiratory disease. Be sure to use appropriate respiratory protection designed to filter out microscopic particles. Be sure to use adequate water pressure.

**Over-exposure to vibration can lead to circulatory and/or nerve damage to the extremities, especially in cold temperatures (Reynaud's Disease).**

If you experience tingling, numbness, pain or changes in skin color, particularly in your fingers, hands or wrists, stop using the power cutter immediately. If the problem persists, seek medical attention.

## THE FOLLOWING WARNING SYMBOL APPLIES TO ALL THE ITEMS LISTED ON THIS PAGE



Indicates a hazard with a low level of risk which, if not avoided, could result in minor or moderate injury.

- Always disconnect the air supply and relieve pressure from supply lines before performing maintenance on the power cutter.
- Diamond chains and guidebar require a minimum water pressure of 20 psi (1.4 bar). Insufficient water supply may result in excessive wear to the guidebar or diamond chain, which can lead to loss of strength and diamond chain breakage and damage the bar.
- When operating a compressor with greater than 90 psi (6 bar) it is recommended to use a "service unit with pressure regulator" in line to prevent over speeding the power cutter.

## GENERAL SAFETY PRECAUTIONS

- Always wear protective clothing, including a hard hat, eye protection, hearing protection and gloves.
- Avoid loose clothing.
- Perform safety checks before starting each day.
- Always operate tool with solid footing and handgrip.
- Remove or control slurry to prevent yourself or others from slipping while cutting.
- Always work in a cleared area.
- Be sure there are no obstructions (plumbing, electrical conduit, air ducts).
- Set up a well-marked safety zone with a roped boundary and clear signs to keep bystanders at least 20 ft (5m) away.
- Breathing exhaust fumes is dangerous. Provide ventilation in closed areas.
- To avoid electrocution, check for live electrical wiring near cutting area.

Weight without bar and chain	29 lbs (13 kg)
Length	20 in (58.5 cm)
Height	10.5 in (26.5 cm)
Width	12 in (30.5cm)
Air Motor Power	6.5 Hp (5 Kw)
Allowable Air Pressure	90psi (6 bar) maximum
Air Supply Requirement @ 90psi (6 bar)	124 cfm (3.5 m <sup>3</sup> /min) minimum
Motor lubrication requirements	Resin and acid-free SAE 5 W to SAE 10 W oil
Water Pressure Requirements	Minimum: 20 psi (1.4 bar)
Water Flow Requirements	1 gpm (4 lpm) minimum
Operating Speed	5,700 rpm (average free running) 4,900 sfm (average free running chain)
Vibration $a_{hv,eq}$ Concrete Cutting <sup>(2)</sup>	Front handle: 5.09 m/s <sup>2</sup> (K=0.2 m/s <sup>2</sup> ) Rear handle: 5.07 m/s <sup>2</sup> (K=0.2 m/s <sup>2</sup> )
Vibration $a_{hv,eq}$ PowerGrit Cutting <sup>(2)</sup>	Front handle: 4.58 m/s <sup>2</sup> (K=0.2 m/s <sup>2</sup> ) Rear handle: 4.43 m/s <sup>2</sup> (K=0.2 m/s <sup>2</sup> )
Guaranteed Sound Power Level $L_{wa}$ <sup>(1)</sup>	113 dB(A); ( $K_{wa}$ =0.5 dB(A))

(1) Measured in accordance with ANSI S12.51-2012/ISO3741:2010

(2) Measured in accordance with ISO5349-1:2001 and ISO22867:2011

- When operating a compressor with pressure greater than 90 psi (6 bar) it is recommended to use a "service unit with pressure regulator" in the line to prevent over speeding the power cutter.

- Always use an in-line oiler (ICS p/n 575130) or air pac (ICS p/n 597279) to provide continuous lubrication to the air motor. This will increase the life of the power cutter and reduce down time.

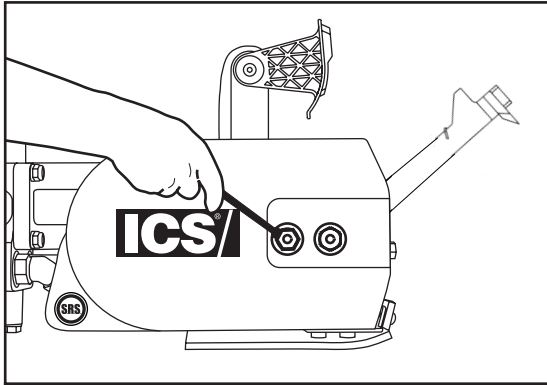
**STEP 1**

Loosen the side cover nuts and remove the side cover and bar clamp plate.

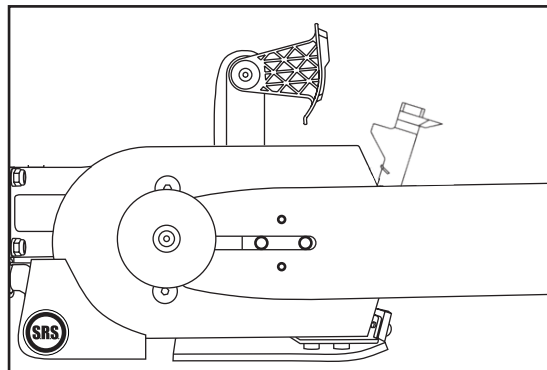
**STEP 2**

Place the bar onto the studs and the chain adjustment pin.

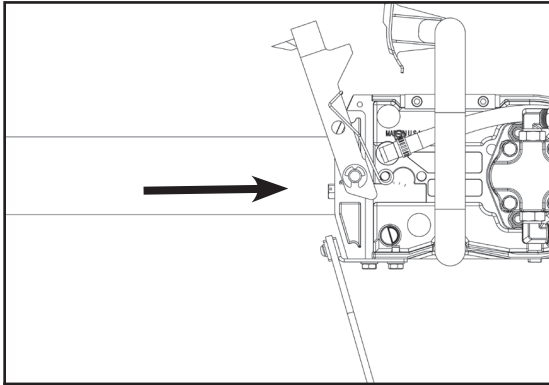
**STEP 3**

Turn the chain-tensioning screw counterclockwise until the bar comes into contact with the drive sprocket.

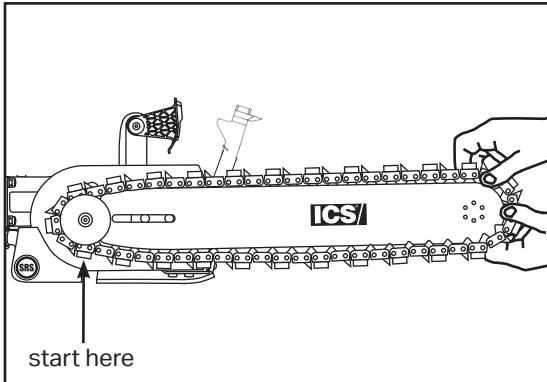
**STEP 4**

Mount the chain on the bar starting at the drive sprocket & continue over the bar nose.

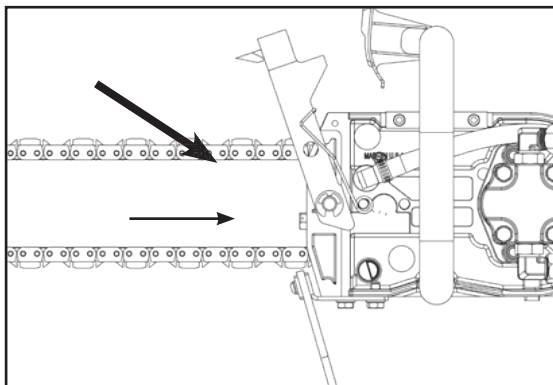
**STEP 5**

Make sure all of the drive links are inside the bar groove, then pre-tension the chain by turning the tensioning screw clockwise.

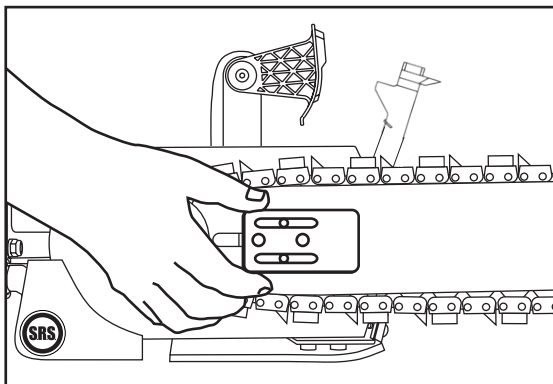
**STEP 6**

Install the bar clamp plate over the bar studs in proper orientation. "Front" is marked on the plate.

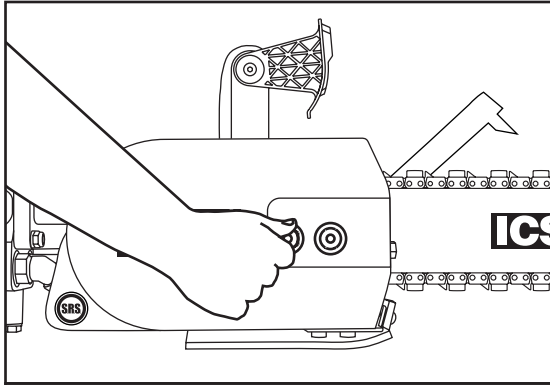
**STEP 7**

Install the side cover over the bar studs and install side cover nuts. Finger tighten only.

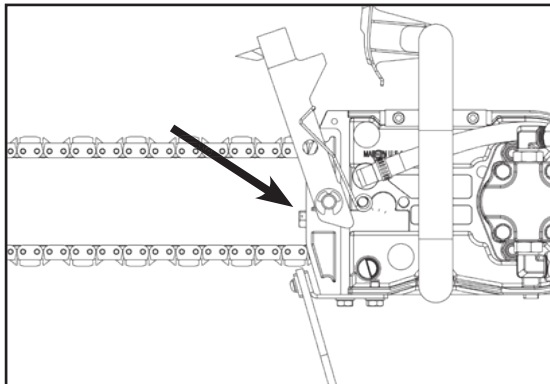
**STEP 8**

Tension the chain properly. Do not over tension the diamond chain. Loss of power will result.

**CAUTION**
**CORRECT CHAIN TENSION**

All chains have a tendency to stretch when used. Diamond chains stretch more than wood cutting chains because of the abrasive materials they are cutting.

If the chain is too tight, more power goes into turning the chain rather than into the cut. In extreme over-tightened cases, the power cutter may not be able to turn the chain at all. In addition, damage can occur to the bar nose and premature stretch may occur.

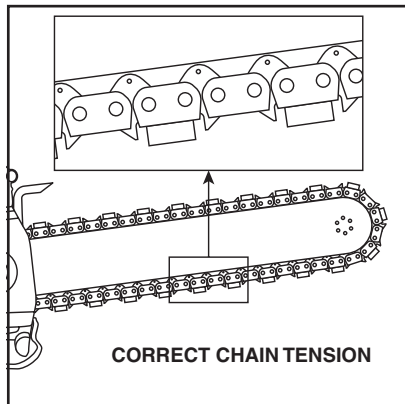
**IMPORTANT**

**CAUTION**
**CHAIN TOO LOOSE**

If the chain is too loose, it could come off the bar, or it will allow the drive sprocket to spin without turning the chain, which can damage drive links.

When a chain stretches to a point where the drive links are hanging approximately 1/2 in (12 mm) to 3/4 in (18 mm) below the bar, it is time to tension the chain.

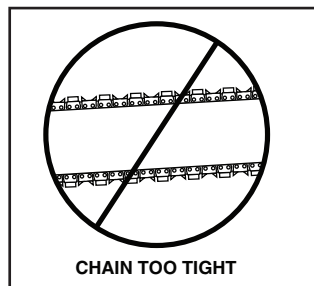
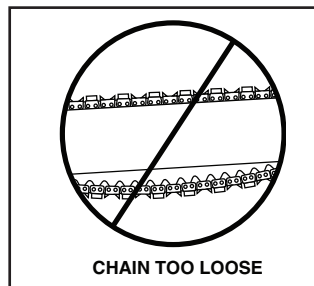



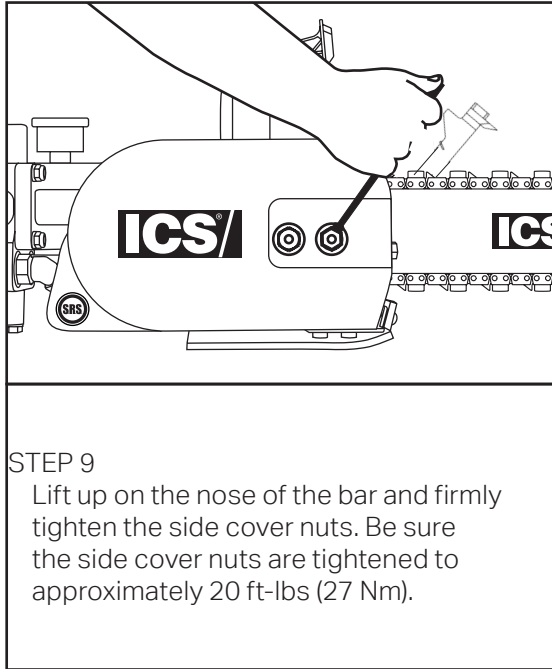

## PRE-CUT CHECKLIST



### CAUTION

**To maximize the life of the cutting system, ensure that proper chain tension is maintained.**

If tension is too tight, it will lead to excessive chain stretch, and a lot of the power cutters power will be used to overcome friction. In severe cases the chain may not turn at all and can lead to chain breakage. If the tension is set too loose, the chain could be thrown off of the bar, or allow the sprocket to turn with out turning the chain, which will damage the drive links.

### PROPER CHAIN TENSION

Concrete cutting power cutters operate with looser chain tension than wood chainsaws. It is common, especially on gas powered, concrete cutting power cutters to have the drive links hang completely out of the bar. Concrete cutting power cutters require water for cooling and flushing the cut. Rotating the chain completely around the bar freely by hand will let you know you have the chain properly tensioned.

### ADDITIONAL TENSIONING TIPS:

1. To reduce chain stretch and tensioning downtime, use 20 psi (1.5 bar) or greater water pressure.
2. Oil the chain at the end of the day to prevent rust but be careful not to over tension in this condition.
3. When pulling the chain around the bar by hand, be sure to wear gloves. The bar rails can be very sharp. Grab only the diamond segments to pull the chain.
4. Always pull the chain away from the WallWalker®. The point of the WallWalker can also be very sharp.



### WARNING

Before tensioning chain, always turn the compressor off and relieve system pressure before disconnecting from the compressor.

**PRE-CUT CHECKLIST, CONT.**

- Adequate Water Supply and Pressure:  
Minimum Flow: 1 gpm (4 lpm)  
Minimum Water Pressure: 20 psi (1.4 bar)  
Checking for water pressure without a pressure gauge: With the compressor off, attach water hose to the power cutter water connection. Pull the chain off to one side of the bar and turn on the water valve. If there is a minimum of 20 psi, water should spray 1 - 3 ft (.3 to 1 m) from the bar.
- Proper Air Supply to the Power Cutter:  
Allowable Air Pressure: 90 (6 bar) maximum  
Air Supply Requirement @ 90psi (6 bar): 124 cfm (3.5 M<sup>3</sup>/min) minimum  
Insure the air supply line is clear before connecting it to the power cutter.  
Dirt and water separators are recommended to prevent rust and condensation from forming in the air lines.
- Motor Lubricator: (Not Included)  
Always use an in-line oiler to provide continuous lubrication to the air motor. The air lubricator or combination lubricator/air drier must be placed 6 to 12 feet (2 - 4 meters) from the tool. This will increase the life of the power cutter and reduce down time.  
Check oil level, when necessary; fill with resin and acid-free SAE 5 W to SAE 10 W oil.

In winter or when using very moist air, use antifreeze lubricant, such as "ICS Prolube ATL/AF", "Killfrost" "BP Energol AX10" or "Kompranol"

 **WARNING**

If cutting pipe with PowerGrit® be sure the cut line stays open by providing proper pipe support. Also check for neighboring utilities or obstructions.

Concrete is very heavy, 1 cubic foot (30 cubic cm) weighs 150 lbs (68 kg). Be sure to cut so that concrete cannot fall and injure operator or bystanders.

Check for live electrical wiring near the cutting area or in the concrete to avoid electrocution which can result in death or serious personal injury.

**PLANNING THE CUT**

- Select the proper chain for the material being cut.
- Outline the cut with a permanent marker for a visual cutting guide.
- Avoid pinching the bar and chain. Always cut the bottom of an opening first, then top, and then the sides. Save the easiest cut for last.

 **CAUTION**

**Wear gloves when handling the bar and chain.** Over time, these components can develop sharp edges and cause cuts.

- When cutting reinforced concrete, be sure you are always cutting concrete as well as rebar. This will prevent the segments from glazing over and keep the diamonds exposed. Also, expect less chain life when cutting concrete with heavy rebar.
- When replacing a chain, flip the guidebar over and dress your guidebar rails to maintain straight cuts. Guidebar rails can be dressed with a flat file or belt sander.
- Note: The normal life of a guidebar is 2 to 3 chains. However, heavy rebar can shorten guidebar life too.
- When using a new chain, cutting speed can be increased by "opening up the diamonds". Make a few plunge cuts in an abrasive material such as a cinder block.

## OPERATING THE DIAMOND POWER CUTTER IN CONCRETE

- When cutting into concrete, plunge cut instead of starting at the top of the wall. This will reduce chatter, extend diamond life, create a straighter cut and more quickly enable the use of the Wallwalker®.
- Always operate a diamond power cutter at full throttle. If too much force is applied, the power cutter will lug or stall and the chain will not have enough speed to cut effectively. If too little force is applied, the diamonds will skid and glaze over.
- For the straightest cuts use the "step cut" method. First score the entire cut line with the nose of the bar approximately ½ inch (12 mm) to 1 inch (25 mm) deep. Next, deepen the cut by about 2 inches (50 mm). This groove will help guide the bar for a straight cut. Then plunge all the way through and complete the cut using the Wallwalker®.
- Use the Wallwalker to cut efficiently and reduce operator fatigue. The Wallwalker when extended is a fulcrum that converts inward force to downward force and will develop a 4-to-1 mechanical advantage. To use correctly, plunge into the wall and simply engage the point of the Wallwalker into the cut and push straight in. The Wallwalker will force the power cutter to feed down.

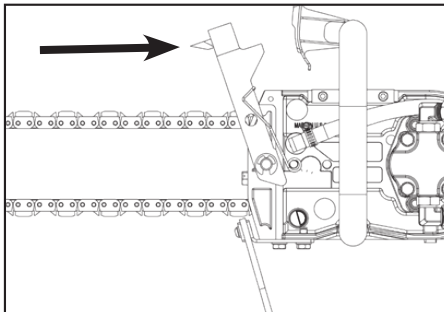

## OPERATING THE DIAMOND POWER CUTTER IN CONCRETE

- When cutting into concrete, plunge cut instead of starting at the top of the wall. This will reduce chatter, extend diamond life, create a straighter cut and more quickly enable the use of the Wallwalker®.
- Always operate a diamond power cutter at full throttle. If too much force is applied, the power cutter will lug or stall and the chain will not have enough speed to cut effectively. If too little force is applied, the diamonds will skid and glaze over.
- For the straightest cuts use the "step cut" method. First score the entire cut line with the nose of the bar approximately ½ inch (12 mm) to 1 inch (25 mm) deep. Next, deepen the cut by about 2 inches (50 mm). This groove will help guide the bar for a straight cut. Then plunge all the way through and complete the cut using the Wallwalker®.
- Use the Wallwalker to cut efficiently and reduce operator fatigue. The Wallwalker when extended is a fulcrum that converts inward force to downward force and will develop a 4-to-1 mechanical advantage. To use correctly, plunge into the wall and simply engage the point of the Wallwalker into the cut and push straight in. The Wallwalker will force the power cutter to feed down.

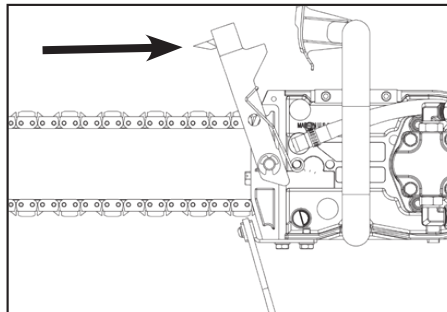

**SYSTEM CLEAN-UP**

1. Run power cutter with water on, for 15 seconds out of cut to flush slurry and debris from chain, bar and drive sprocket.
2. Wash concrete slurry from power cutter body.
3. Remove bar and chain. Flush out chain tensioner assembly location with high water pressure and lube with grease.
4. Clean all air fittings on power cutter and compressor.
5. When done cleaning power cutter, spray entire power cutter body, chain, bar, and drive sprocket with a lightweight penetrating oil. This will minimize rust and reduce slurry build up on power cutter assembly.

- **SLOW CHAIN SPEED** - Be sure the compressor is providing the correct air pressure at the power cutter (90 psi = 6 bar) and cubic feet per minute (124 cfm = 3.5 m<sup>3</sup>/min). Chain is installed too tight. Refer to tension on page 11. Low oil or no oil is getting to the motor. Make sure the drops per minute (DPM) is set between 10 & 15.
- **CONCRETE CHAIN - POOR CUTTING PERFORMANCE** - Diamonds may be "glazed over". Make a few plunge cuts in an abrasive material such as a cinder block to expose the diamonds.
- **UTILITY CHAIN - POOR CUTTING PERFORMANCE** - PowerGrit® chain is worn out. Make sure the diamonds are intact and exposed. DO NOT use PowerGrit for cutting steel.
- **PREMATURE CHAIN STRETCH** - Not enough water pressure, the minimum water pressure is 20 psi (1.4 bar). Insufficient water supply will result in excessive wear on the chain, which can lead to loss of strength and chain breakage. Cutting with the guidebar nose buried in the cut, in sand, gravel, pipe or using with improper chain tension will all contribute to increased chain stretch.

*NOTE: This applies to PowerGrit chains also.*

- **CHAIN TENSIONER BREAKAGE** - Side cover nuts are not tight enough, or tensioning was attempted with side cover nuts already fully tightened.
- **WATER NOT FLOWING** - Water hose is kinked, blockage in guidebar water ports, or supply is not turned on.
- **MOTOR DOES NOT START**
  - Insufficient air supply. Check compressor and air hose, valves, and air inlet screen for blockage.
  - Chain tension is too tight, loosen chain tension.
  - Iced exhaust. wait until ice thaws, then use anti-freeze lubricant
  - Vanes sticky. Apply lubricant directly to power cutter air inlet and blow motor clear. Repeat if necessary. See maintenance instructions

### Further questions?

**Call 800.321.1240 or visit our website at: [icsdiamondtools.com](http://icsdiamondtools.com)**



## DRIVE SPROCKET INSTALLATION

### STEP 1

- Remove snap ring
- Remove sprocket
- Install sprocket in reverse order ensuring counter bore is facing out.
- Install snap ring

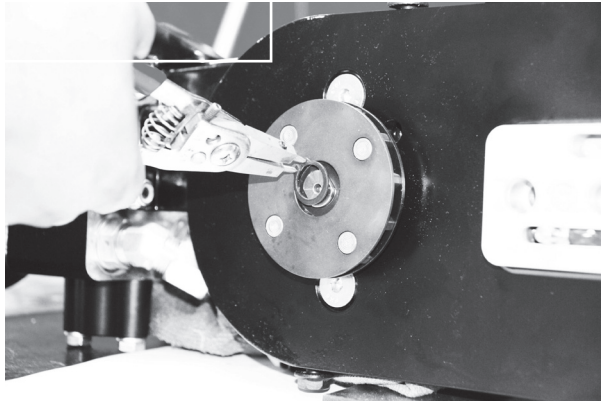

### STEP 2

- Ensure snap ring is fully seated in snap ring groove.

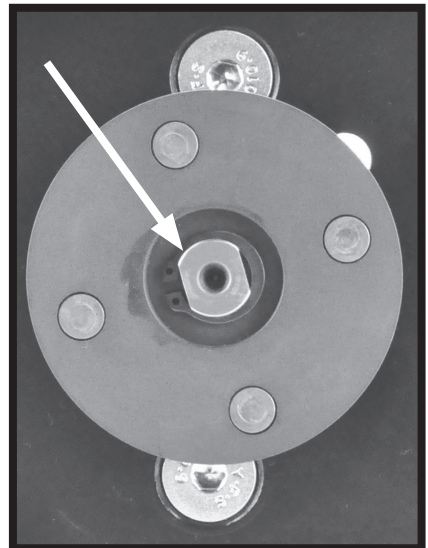

## AIR MOTOR MAINTENANCE

Service life and performance of the chain power cutter are determined by:

1. Degree of air purity
2. Lubrication
3. Maintenance

Prior to operating the power cutter be sure to:

1. Blow the air hose clear prior to connecting it to the power cutter. Install dirt and water separators upstream of the power cutter 6 - 12 ft (2 - 4 m).
2. Install an air lubricator upstream of the power cutter and fill it with SAE 5 W to SAE 10 W oil. Optimum lubrication significantly prolongs service life.
3. Regularly check and clean the air inlet screen.
4. Replace wear parts - in particular the motor vanes. It is suggested to replace the motor vanes if their width is less than 1.083 in. (27.5 mm). Motor maintenance should be performed by a qualified air tool service facility.
5. Check oil level, when necessary; fill with resin and acid-free SAE 5 W to SAE 10 W oil.
6. In winter or when using very moist air, use antifreeze lubricant, such as: "ICS Prolube ATL/AF", "Killfrost" "BP Energol AX10" or "Kompranol.
7. Air lubricator (oiler) can be adjusted to maximize atomization and minimize excessive oil use.

## APPROXIMATE CUTTING RATES

Material	Cutting Rate
Concrete – 6 in (15 cm)	5 lineal in/min (12 cm/min)
Red Brick – 6 in (15 cm)	10 lineal in/min (25 cm/min)
Rebar – #4 (12 mm)	10–20 seconds through each piece
*Rebar must be encased in concrete, never cut bare rebar with ICS Diamond Chain.	

## INCH-FOOT DEFINITION

An in-ft is a measure of how much material is to be cut.  
An in-ft is defined as: depth in inches times length in feet.

Note:  $129 \text{ in-ft} = 1 \text{ m}^2$

Example: How many in-ft are in this doorway?

1. Determine the depth of the cut in inches.  
For this example, 8 inches.
2. Determine the length of the cut in feet.  
 $3+7+3=20$  feet
3. Multiply the two numbers  
 $8 \text{ in} \times 20 \text{ ft} = 160 \text{ in-ft}$

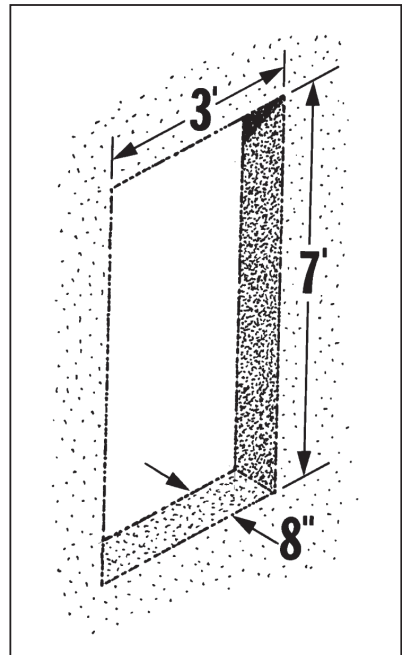



### EC- DECLARATION OF CONFORMITY

**MANUFACTURER:**  
**Blount International Inc.**  
4909 SE International Way  
Portland Oregon, 97222 USA

DECLARES THAT THE FOLLOWING PRODUCT(S):

**Brand Name:** ICS  
**Model Number:** 701-A  
**Equipment Name:** Air Saw



**MEETS OR EXCEEDS THE REQUIREMENTS IN THE FOLLOWING EUROPEAN DIRECTIVE(S) AND/OR STANDARD(S):**  
Machinery Directive 2006/42/EC  
Registration, Evaluation, Authorization and Restriction of Chemicals (REACH) 1907/2006  
Restriction of Hazardous Substances (RoHS) 2002/95/EC  
Safety Of Machinery - General Principles for Design - Risk Assessment and Risk Reduction EN/ISO20100:2010  
Mechanical vibration – Measurement and evaluation of human exposure to hand-transmitted vibration EN/ISO 5349-1:2001  
Acoustics – Sound power using sound pressure EN/ISO 3744:2010  
Noise Directive (ODN) 2000/14/EC according to ANNEX V  
Measured Sound Power,  $L_{pA} = 112 \text{ dB(A)}$   
Uncertainty,  $K = 0.5 \text{ dB(A)}$   
Calculated Guaranteed Sound Power,  $L_{WA} = 113 \text{ dB(A)}$

CLARIFICATION OF PRODUCT CLASS: The ICS 701A Air Saw, using the appropriate genuine ICS Diamond Chain, is designed to ONLY cut concrete or designated materials other than wood. The cutting means is by grinding through the work piece, using a continuous water supply as a coolant and lubricant. This product is not intended for use with conventional wood cutting saw chain.

By design, this product is not intended to comply with the definition of a chain-saw as described by ISO 6531 – “Machinery for Forestry – Portable hand held chain saws – Vocabulary”:  
ISO6531-1999; Clause 2.2.1; chain saw: “power driven tool designed to cut wood with a saw chain and consisting of an integrated compact unit of handles, power source, and cutting attachment, designed to be supported with two hands”

**Corporate Representative:**  
  
John DeHaven  
Product Safety & Compliance Manager  
Blount International Inc. Portland Or. 97222 USA

**Manufacturer’s Representative in the EC:**  
Mr. Marnix Kuypers  
Blount International-Europe-S.A.  
Rue Emile Francqui, 5  
1435 Mont-Saint-Guilbert  
Belgium

**Date / Place:**  
27APR2015, Portland OR. USA

4909 SE INTERNATIONAL WAY | PORTLAND, OREGON 97222 | 503.653.8881

**ICS, OREGON TOOL INC.  
4909 SE INTERNATIONAL WAY  
PORTLAND, OR 97222  
800.321.1240  
[icsdiamondtools.com](http://icsdiamondtools.com)**